

NMR 15WN SS Assembly

Call 800-321-7800 or visit us online at www.nookindustries.com to configure and order your NMR 15WN SS Assembly today!

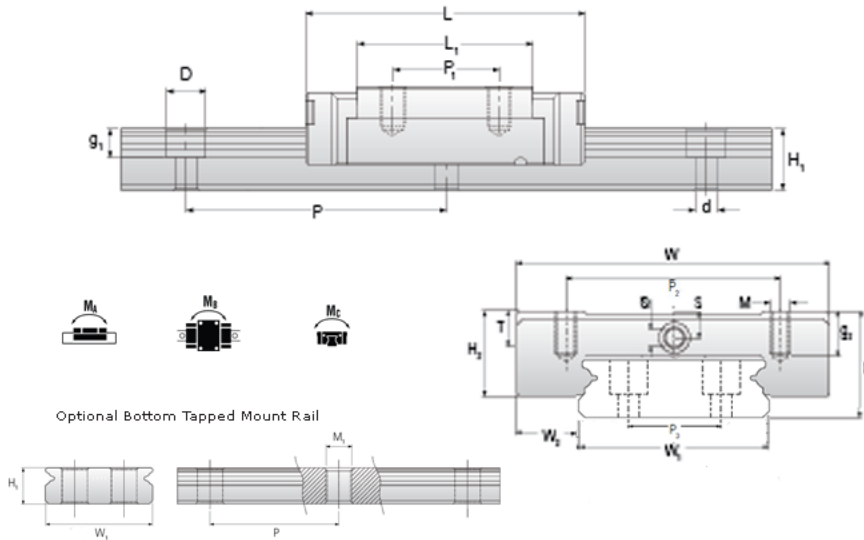
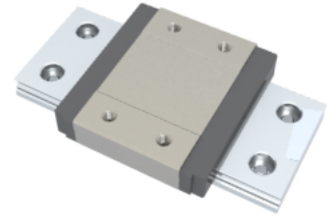

Dimensions

H [mm]	16
W2 [mm]	9

Wide Miniature Block Four Mounting Holes (Runner Block)Details

Size [mm]	15
-----------	----

(Runner Block)Dimensions

W [mm]	60
L [mm]	55.3
L1 [mm]	38.5
h2 [mm]	12
P1 [mm]	20
P2 [mm]	45
M × g2	M4 × 4.5
Ø [mm]	1.8
S [mm]	3.3
T [mm]	4.5

(Runner Block)Forces and Torques

Basic Load Ratings C [N]	5065
Basic Load Ratings C0 [N]	8385
Static Moment Ratings-Ma [N-m]	45.7
Static Moment Ratings-Mb [N-m]	45.7
Static Moment Ratings-Mc [N-m]	171.7

(Runner Block)Weight

Weight-Block [g]	137
------------------	-----

Wide Miniature Rail Top Mount Double Row (Top Mount Rail)Details

Size [mm]	15
-----------	----

(Top Mount Rail)Dimensions

H [mm]	16
W1 [mm]	42
H1 [mm]	9.5
P [mm]	40
P3 [mm]	23
D [mm]	8
d1 [mm]	4.5
g1 [mm]	4.5

(Top Mount Rail)Weight

Weights-Rail [g/m]	2818.0
--------------------	--------

Wide Miniature Rail Bottom Tapped Mount Double Row (Bottom Mount Rail)Details

Size [mm]	15
-----------	----

(Bottom Mount Rail)Dimensions

H1 [mm]	9.5
W1 [mm]	42
P [mm]	40
P3 [mm]	23
M1	M5 x 0.8

