

## G2-MSJ-UR 2:1

Call 800-321-7800 or visit us online at [www.nookindustries.com](http://www.nookindustries.com) to configure and order your G2-MSJ-UR 2:1 today!

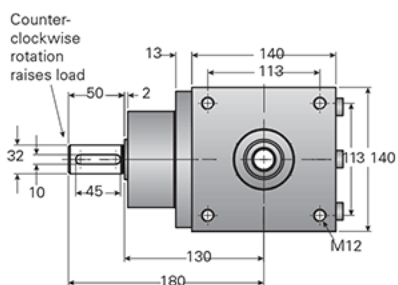

For ordering, specify "L" dimension  
 $L(\text{min}) = \text{Travel} + 331$

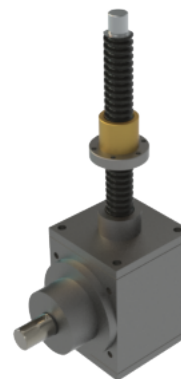
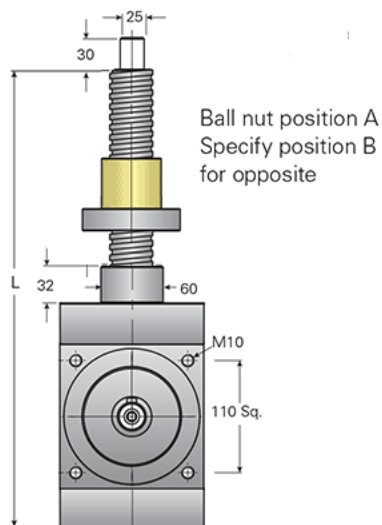
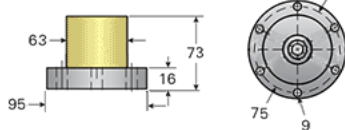

### Details

Capacity [kN]	44.5
Gear Ratio	2:1
Raise for One Turn of Worm [mm]	3.50
Torque to Raise 1 kN [Nm]	1.39
Tare Drag Torque [Nm]	2.30
Lifting Screw Diameter [mm]	40
Screw Lead [mm]	7
BackDrive Holding Torque [Nm]	6.61

### Performance Specifications

Maximum Input Torque [Nm]	175
---------------------------	-----

### Weight

Base 0 Travel [kg]	15.90
Per 100mm of Travel [kg]	0.81
Grease [kg]	0.45