

## ND8-12-10-B

Call 800-321-7800 or visit us online at [www.nookindustries.com](http://www.nookindustries.com) to configure and order your ND8-12-10-B today!

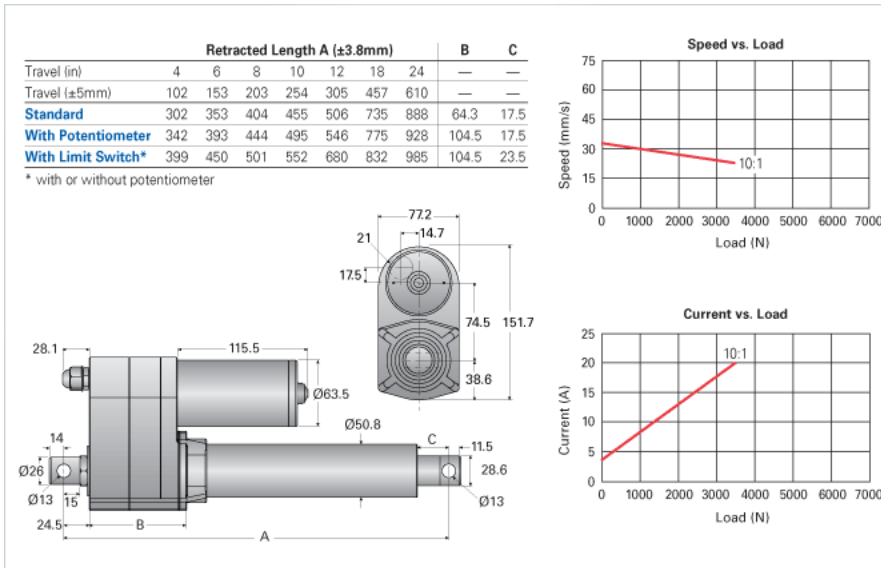

### Product Info

Screw Type

Ball Screw

### Details

Voltage [VDC]

12

Gear Ratio

10:1

Speed At No Load [mm/s]

33.5

Speed At Full Load [mm/s]

26.7

Load Capacity Dynamic Load [N]

3500

Load Capacity Static Load [N]

13600

Amps

20

### Performance Specifications

Duty Cycle [% of 5 Minutes]

25

Protection Class

IP65