

## DLZA 160 Extended Carriage, Six Split Rollers

Call 800-321-7800 or visit us online at [www.nookindustries.com](http://www.nookindustries.com) to configure and order your DLZA 160 Extended Carriage, Six Split Rollers today!

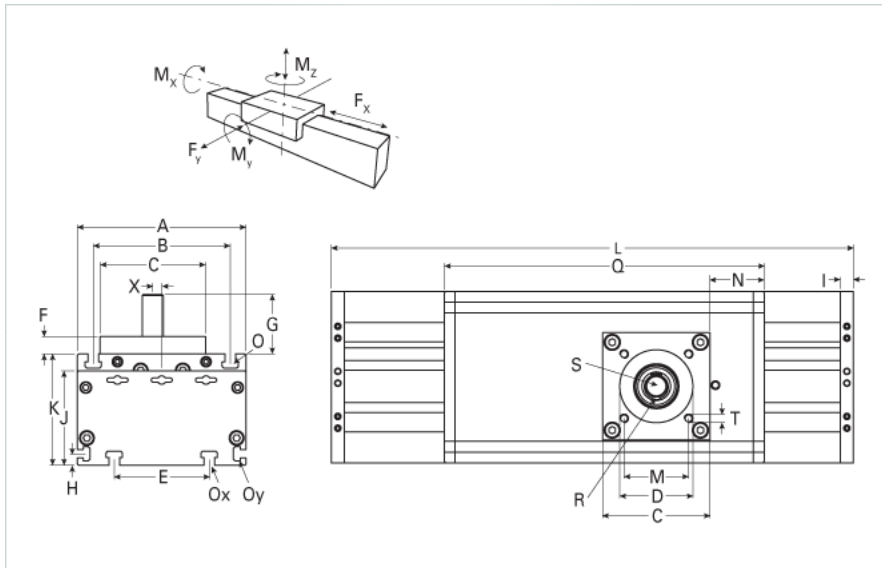
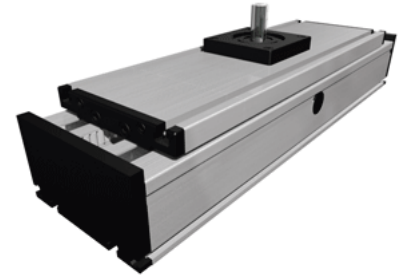

### Details

Size 160

### Dimensions

Basic Length L [mm]	340
A [mm]	160
B [mm]	130
C [mm]	100
D [mm]	68
E [mm]	90
F [mm]	16.5
G [mm]	56.5
H [mm]	11
J [mm]	90
K [mm]	106
M	60
N	59
O	M8
Ox	M8
Oy	M6
P [mm]	12
Q [mm]	300
T	M8
U [mm]	80
X [mm]	8.5

### Speed

Speed Maximum [m/s] 3

### Forces and Torques

No-load torque [Nm]	1.5
Tensile force 0.2 sec [N]	2090
Tensile force permanent [N]	1900
Fx dynamic [N]	1800
Fy dynamic [N]	2000
Fz dynamic [N]	2800
Mx dynamic [Nm]	320
My dynamic [Nm]	300
Mz dynamic [Nm]	150
Fx static [N]	1900
Fy static [N]	3000
Fz static [N]	3500
Mx static [Nm]	400
My static [Nm]	360
Mz static [Nm]	180

### Geometrical moments of inertia of aluminum profile

Elastic modulus [N/mm <sup>2</sup> ]	70000
Ix [mm <sup>4</sup> ]	2220000
Iy [mm <sup>4</sup> ]	12200000

### Weight

Additional Weight per 100 mm [kg] 2.10

