

ELZA 100 WAC Extended Carriage

Call 800-321-7800 or visit us online at www.nookindustries.com to configure and order your ELZA 100 WAC Extended Carriage today!

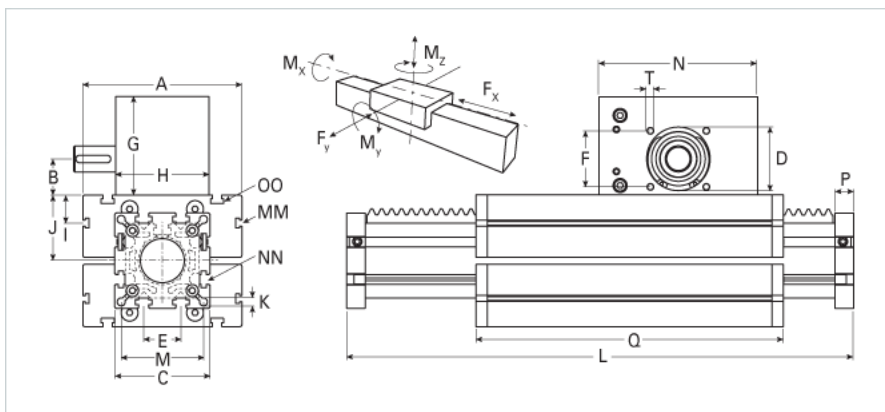
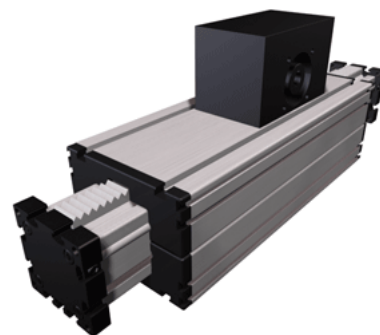

Details	
Size	100
Dimensions	
Basic Length L [mm]	581
A [mm]	230
B [mm]	55.3
C [mm]	130
D [mm]	90
E [mm]	50
F [mm]	80
G [mm]	155
H [mm]	120
I [mm]	29
J [mm]	89
K [mm]	10.5
M [mm]	112
MM	M10
N [mm]	240
NN	M10
OO	M10
P [mm]	30
Q [mm]	521
T	M10
X [mm]	-
Speed	
Speed Maximum [m/s]	3
Forces and Torques	
Fx dynamic [N]	2500
Fy dynamic [N]	6500
Fz dynamic [N]	2200
Mx dynamic [Nm]	230
My dynamic [Nm]	270
Mz dynamic [Nm]	500
Fx static [N]	2900
Fy static [N]	8000
Fz static [N]	3600
Mx static [Nm]	300
My static [Nm]	400
Mz static [Nm]	750
Geometrical moments of inertia of aluminum profile	
Elastic modulus [N/mm ²]	70000
Ix [mm ⁴]	4440000
Iy [mm ⁴]	4480000
Weight	
Additional Weight per 100 mm [kg]	1.75
Basic Weight [kg]	24.0