

RAD-20048-HL/30XX

Call 800-321-7800 or visit us online at www.nookindustries.com to configure and order your RAD-20048-HL/30XX today!

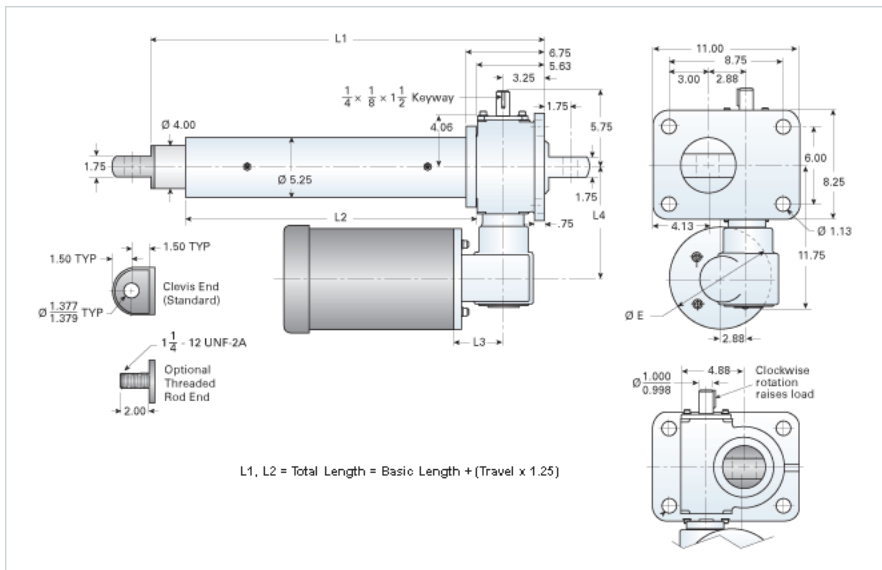

Details

| | |
|--------------------------------|-------------|
| Screw Options | 24x5/24x10 |
| Screw Type | Trapexoidal |
| Gear Ratio Primary Reduction | 24:1 |
| Gear Ratio Secondary Reduction | 8:1 |
| Input Turns Per Inch Of Travel | 192 |
| Torque To Raise 1 lb. [in-lb] | 0.0031 |
| Max Capacity [lb] | 40000 |
| Max HP [hp] | 3 |

Performance Specifications

| | |
|--|--------|
| Travel Rate [in/min] | 9 |
| Dynamic Capacity [lb] | 35000 |
| Rated Life [in] | 440000 |
| Motor Horse Power | 3 |
| Maximum Rod Reaction Torque [in-lb] | 6195 |
| Std. Brake Torque [ft-lb] | 15 |
| Approximate Stopping Distance No Load [in] | 0.02 |
| Approximate Stopping Distance Full Load [in] | 0.02 |

Weight

| | |
|-------------------------|------|
| Basic Weight [lb] | 202 |
| Per Inch of Travel [lb] | 3.31 |

Tube Dimensions

| | |
|----------------------|-------|
| L1 Basic Length [in] | 21.13 |
| L2 Basic Length [in] | 12.63 |

NEMA 56C Dimensions

| | |
|---------|---|
| L3 [in] | - |
| L4 [in] | - |
| E [in] | - |

NEMA 180TC Dimensions

| | |
|---------|------|
| L3 [in] | 6.12 |
| L4 [in] | 9.00 |
| F [in] | 9.12 |