

QSSR 100 Extended Carriage

Call 800-321-7800 or visit us online at www.nookindustries.com to configure and order your QSSR 100 Extended Carriage today!

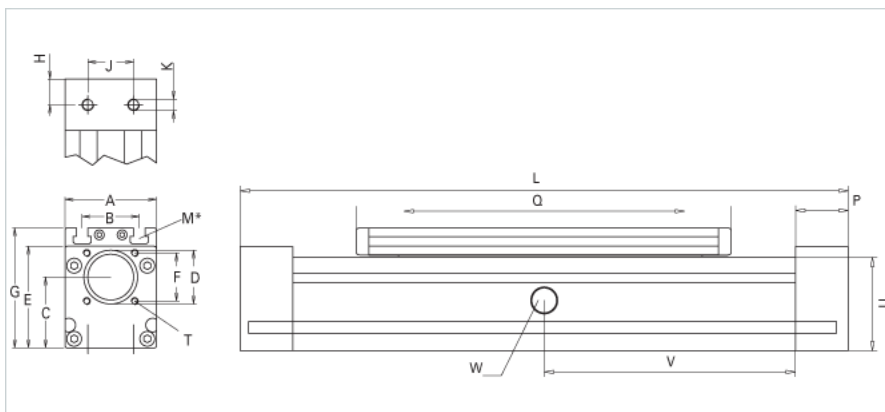
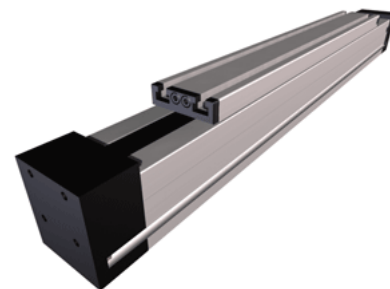

Details	
Size	100
Dimensions	
Basic Length L [mm]	510
A [mm]	100
B [mm]	66
C [mm]	75
D [mm]	68
G [mm]	129
H [mm]	28.5
J [mm]	50
K	M10
M	M10
P [mm]	57
Q [mm]	383
T	M8
U [mm]	100
Forces and Torques	
Fy [N] 10000 km	2900
Fz [N] 10000 km	7270
Mx [Nm] 10000 km	101
My [Nm] 10000 km	597
Mz [Nm] 10000 km	532
Fy [N] 5000 km	4080
Fz [N] 5000 km	10300
Mx [Nm] 5000 km	142
My [Nm] 5000 km	838
Mz [Nm] 5000 km	745
Geometrical moments of inertia of aluminum profile	
Elastic modulus [N/mm ²]	70000
Ix [mm ⁴]	4300000
Iy [mm ⁴]	4880000
Weight	
Weight Per 100 mm [kg]	1.2
Basic Weight [kg]	10.2