

## QSSR 60 Extended Carriage

Call 800-321-7800 or visit us online at [www.nookindustries.com](http://www.nookindustries.com) to configure and order your QSSR 60 Extended Carriage today!

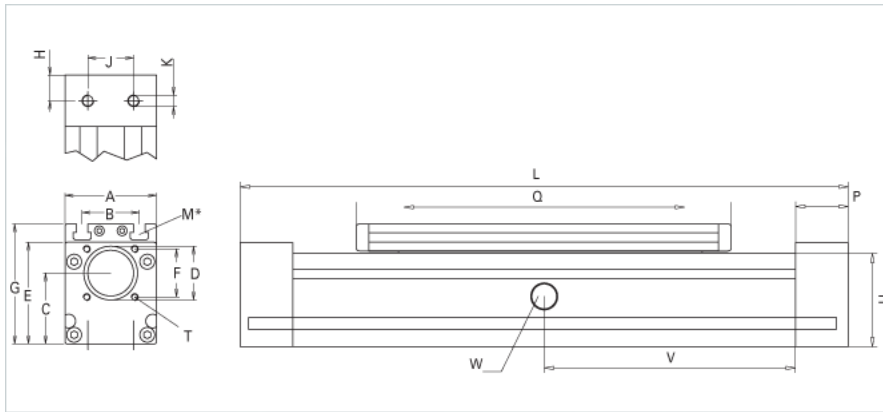
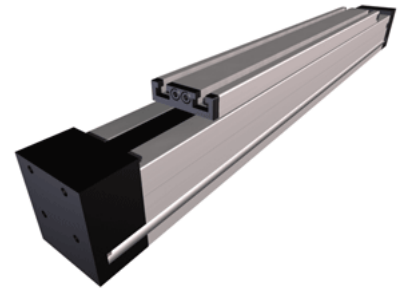

Details	
Size	60
Dimensions	
Basic Length L [mm]	350
A [mm]	60
B [mm]	36
C [mm]	45
D [mm]	37
G [mm]	79
H [mm]	19
J [mm]	18
K	M6
M	M6
P [mm]	38
Q [mm]	255
T	M5
U [mm]	60
Forces and Torques	
Fy [N] 10000 km	990
Fz [N] 10000 km	2500
Mx [Nm] 10000 km	23
My [Nm] 10000 km	143
Mz [Nm] 10000 km	125
Fy [N] 5000 km	1410
Fz [N] 5000 km	3520
Mx [Nm] 5000 km	33
My [Nm] 5000 km	190
Mz [Nm] 5000 km	176
Geometrical moments of inertia of aluminum profile	
Elastic modulus [N/mm <sup>2</sup> ]	70000
Ix [mm <sup>4</sup> ]	430000
Iy [mm <sup>4</sup> ]	480000
Weight	
Weight Per 100 mm [kg]	0.3
Basic Weight [kg]	3.1