

QST 60 Dual Carraige Extended Carriage

Call 800-321-7800 or visit us online at www.nookindustries.com to configure and order your QST 60 Dual Carraige Extended Carriage today!

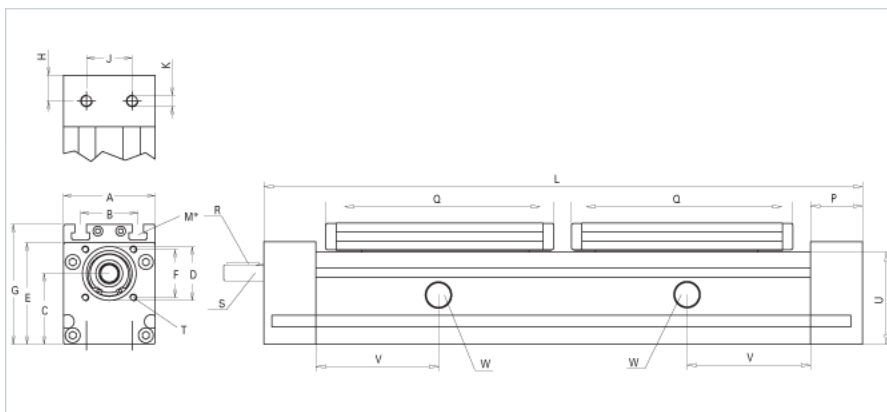

Details	
Size	60
Screw Options	18x4/18x8
Screw Type	Trapexoidal
Dimensions	
Basic Length L with Divided Screw [mm]	630
Basic Length L with Twin Lead Screw [mm]	590
A [mm]	60
B [mm]	36
C [mm]	45
D [mm]	37
E [mm]	67
F [mm]	32
G [mm]	79
H [mm]	19
J [mm]	18
K	M6
M	M6
P [mm]	38
Q [mm]	188
Shaft R Key [mm]	3x3x25
Shaft S Diameter x Length [mm]	10h6x27
T	M5
U [mm]	60
Forces and Torques	
Fx [N] 10000 km	800
Fy [N] 10000 km	1010
Fz [N] 10000 km	2510
Mx [Nm] 10000 km	23
My [Nm] 10000 km	143
Mz [Nm] 10000 km	125
Fx [N] 5000 km	900
Fy [N] 5000 km	1415
Fz [N] 5000 km	3525
Mx [Nm] 5000 km	33
My [Nm] 5000 km	190
Mz [Nm] 5000 km	176
Geometrical moments of inertia of aluminum profile	
Elastic modulus [N/mm ²]	70000
Ix [mm ⁴]	430000
Iy [mm ⁴]	480000
Weight	
Additional Weight per 100 mm [kg]	0.5
Basic Weight [kg] [.0]	5.4