

DLSZ 200 Extended Carriage 6 Split Rollers

Call 800-321-7800 or visit us online at www.nookindustries.com to configure and order your DLSZ 200 Extended Carriage 6 Split Rollers today!

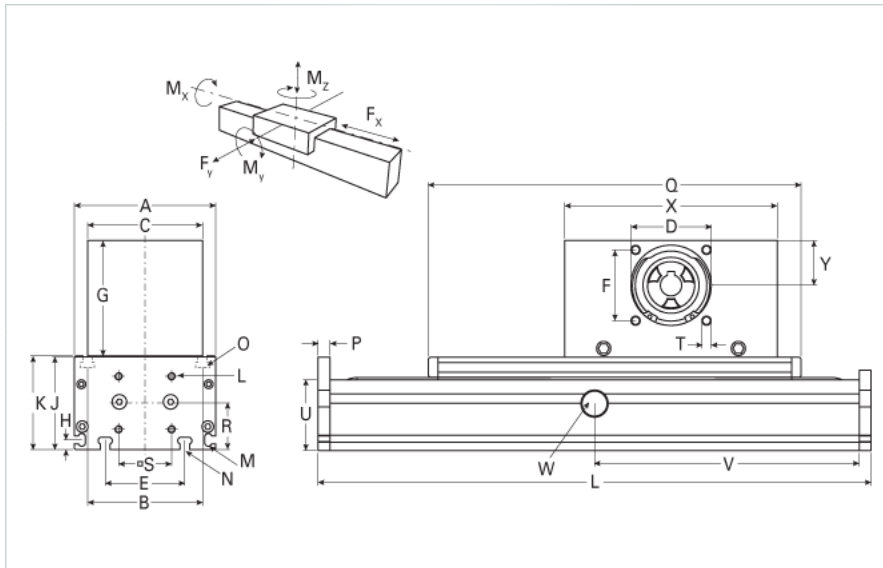
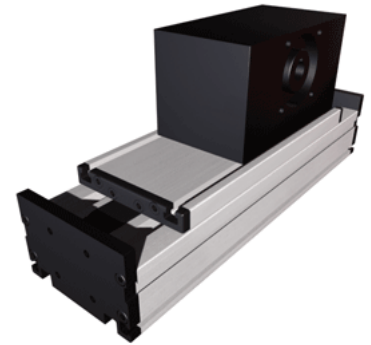

Details

Size	200
Belt	8M70
mm/Rev	304
Number of Teeth	38
Pully Diameter [mm]	96.8

Dimensions

Basic Length L [mm]	520
A [mm]	200
B [mm]	160
C [mm]	160
D [mm]	110
E [mm]	140
F [mm]	100
G [mm]	145
H [mm]	15
J [mm]	128
K [mm]	129
M	M8
N	M10
O	M10
P [mm]	15
Q [mm]	480
R [mm]	69
S [mm]	95
T	M10
U [mm]	100
X [mm]	310
Y [mm]	62
Shaft Diameter and Length [mm]	30 x 55
Key	8x7x50

Speed

Speed Maximum [m/s]	8
---------------------	---

Forces and Torques

No-load torque [Nm]	1.8
Tensile force 0.2 sec [N]	6350
Tensile force permanent [N]	5900
Fx dynamic [N]	5750
Fy dynamic [N]	3100
Fz dynamic [N]	4400
Mx dynamic [Nm]	510
My dynamic [Nm]	480
Mz dynamic [Nm]	275
Fx static [N]	5900
Fy static [N]	4400
Fz static [N]	4900
Mx static [Nm]	600
My static [Nm]	560

Mz static [Nm]	310
Geometrical moments of inertia of aluminum profile	
Elastic modulus [N/mm ²]	70000
Ix [mm ⁴]	6380000
Iy [mm ⁴]	33500000
Weight	
Additional Weight per 100 mm [kg] [.00}	2.6
Basic Weight [kg]	53.0