

## DLZ 160 Extended Carriage 6 Split Rollers

Call 800-321-7800 or visit us online at [www.nookindustries.com](http://www.nookindustries.com) to configure and order your DLZ 160 Extended Carriage 6 Split Rollers today!

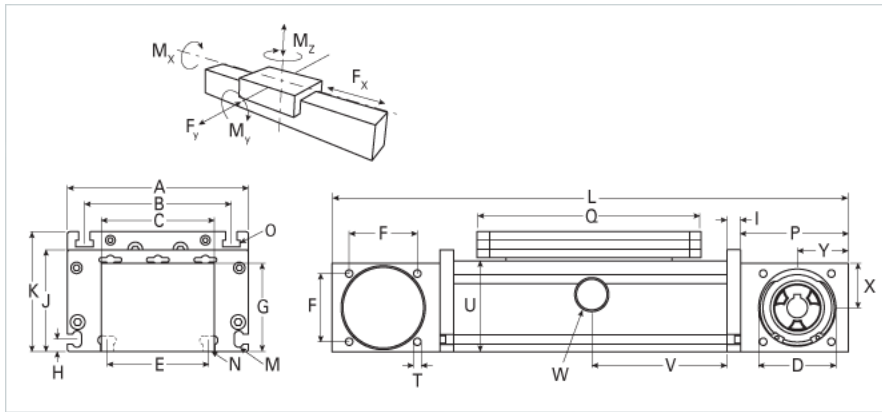
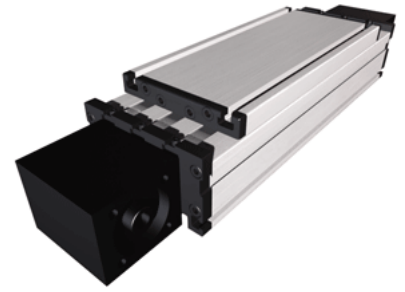

### Details

Size	160
Belt	8M30/8M50
mm/Rev	176
Number of Teeth	22

### Dimensions

Basic Length L [mm]	540
A [mm]	160
B [mm]	130
C [mm]	100
D [mm]	68
E [mm]	90
F [mm]	60
G [mm]	78
H [mm]	11
I [mm]	12
J [mm]	90
K [mm]	106
M	M6
N	M8
O	M8
P [mm]	95
Q [mm]	3000
T	M8
U [mm]	80
X [mm]	39
Y [mm]	45

### Speed

Speed Maximum [m/s]	6
---------------------	---

### Forces and Torques

No-load torque [Nm]	3.8
Tensile force 0.2 sec [N]	2090
Tensile force permanent [N]	1900
Fx dynamic [N]	1800
Fy dynamic [N]	2000
Fz dynamic [N]	2800
Mx dynamic [Nm]	320
My dynamic [Nm]	300
Mz dynamic [Nm]	150
Fx static [N]	1900
Fy static [N]	3000
Fz static [N]	3500
Mx static [Nm]	400
My static [Nm]	360
Mz static [Nm]	180

### Geometrical moments of inertia of aluminum profile

Elastic modulus [N/mm <sup>2</sup> ]	70000
Ix [mm <sup>4</sup> ]	2220000
Iy [mm <sup>4</sup> ]	12200000

### Weight

Additional Weight per 100 mm [kg]	1.69
Basic Weight [kg]	13.0

### Values for Calculating Inertias

Pulley Material	Aluminum
-----------------	----------

Pulley Diameter [mm]	56.02
Effective Pulley Width [mm]	100
Belt Weight [kg/m]	0.256
Standard Carriage Weight [kg]	7.59
No-load torque (w/cover bands) [Nm]	2.1
No-load torque (w/o cover bands) [Nm]	1.5
Friction Coefficient	0.01