

QLZ 80 Extended Carriage 6 Split Rollers

Call 800-321-7800 or visit us online at www.nookindustries.com to configure and order your QLZ 80 Extended Carriage 6 Split Rollers today!

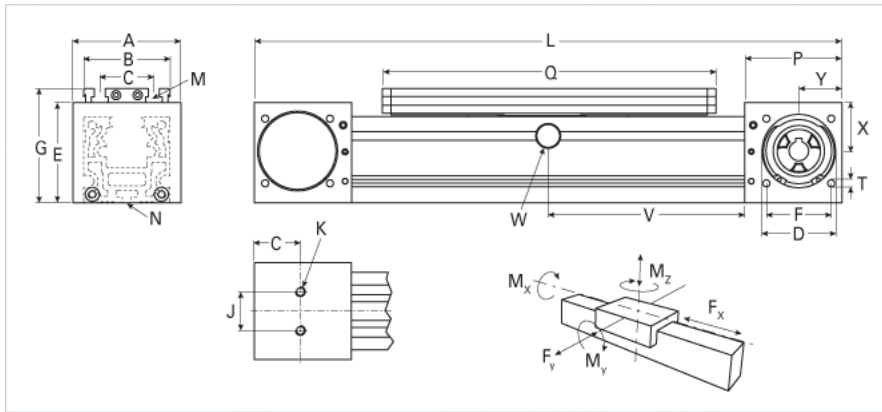
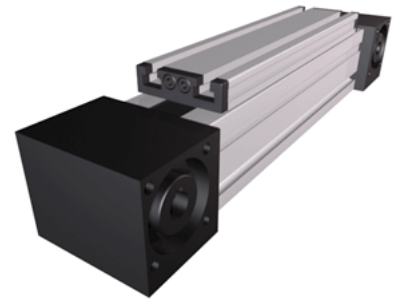

Details

Size	80
Belt	8M30
mm/Rev	176
Number of Teeth	22

Dimensions

Basic Length L [mm]	490
A [mm]	100
B [mm]	80
C [mm]	50
D [mm]	68
E [mm]	93
F [mm]	60
G [mm]	106
H [mm]	47.5
J [mm]	40
K	M10
M	M8
N	M6
P [mm]	90
Q [mm]	296
T	M8
X [mm]	45
Y [mm]	40
Shaft Diameter and Length [mm]	18 x 45
Key	6x6x40

Speed

Speed Maximum [m/s]	6
---------------------	---

Forces and Torques

No-load torque [Nm]	0.8
Tensile force 0.2 sec [N]	2090
Tensile force permanent [N]	1900
Fx dynamic [N]	800
Fy dynamic [N]	1240
Fz dynamic [N]	1200
Mx dynamic [Nm]	40
My dynamic [Nm]	80
Mz dynamic [Nm]	60
Fx static [N]	894
Fy static [N]	1600
Fz static [N]	1500
Mx static [Nm]	50
My static [Nm]	100
Mz static [Nm]	75

Geometrical moments of inertia of aluminum profile

Elastic modulus [N/mm ²]	70000
Ix [mm ⁴]	1650000
Iy [mm ⁴]	1870000

Shaft Details

Key [mm]	6x6x40
Shaft Diameter h6 x Length [mm]	18 x 45

Weight

Additional Weight per 100 mm [kg]	0.78
Basic Weight [kg]	9.6

Values for Calculating Inertias

Pulley Material	Steel
Pulley Diameter [mm]	56.02
Effective Pulley Width [mm]	100
Belt Weight [kg/m]	0.256
Standard Carriage Weight [kg]	1.61
No-load torque [Nm]	0.8
Friction Coefficient	0.01