

ELVZ 60 WAC Dual Carriage

Call 800-321-7800 or visit us online at www.nookindustries.com to configure and order your ELVZ 60 WAC Dual Carriage today!

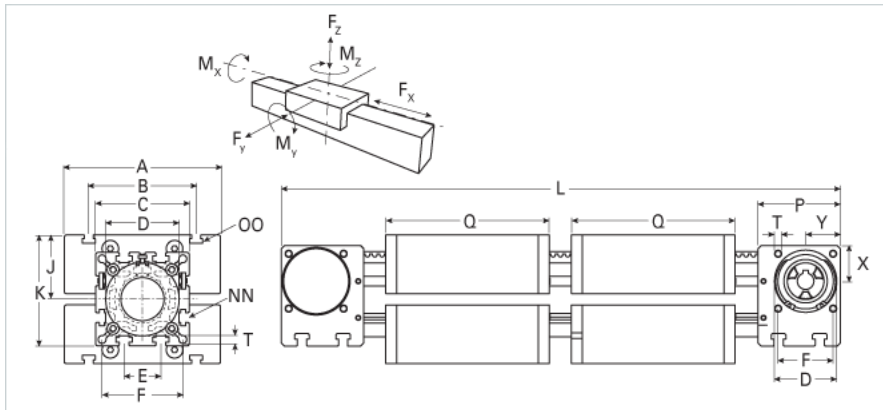
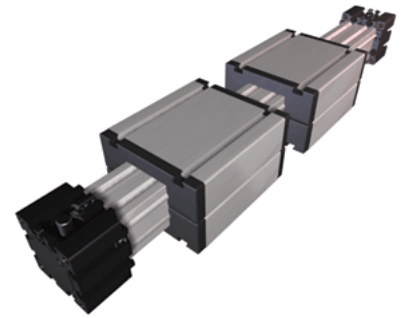

Details

Size	60
Belt	5M25
mm/Rev	80
Number of Teeth	16
Pully Diameter [mm]	25.5

Dimensions

Basic Length L [mm]	492
A [mm]	144
B [mm]	96
C [mm]	82
D [mm]	62x1
E [mm]	30
F [mm]	69
G [mm]	-
H [mm]	-
J [mm]	49
K [mm]	90
MM	-
NN	M8
OO	M8
P [mm]	59
Q [mm]	184
T [mm]	8.5
U [mm]	23
V [mm]	37
W [mm]	14
X [mm]	30
Y [mm]	36
Z	M6
Shaft Diameter and Length [mm]	14 x 35
Key	5x5x28

Speed

Speed Maximum [m/s]	3
---------------------	---

Forces and Torques

No-load torque [Nm]	0.5
Tensile force 0.2 sec [N]	800
Tensile force permanent [N]	700
Fx dynamic [N]	580
Fy dynamic [N]	2000
Fz dynamic [N]	1100
Mx dynamic [Nm]	43
My dynamic [Nm]	70
Mz dynamic [Nm]	100
Fx static [N]	700
Fy static [N]	3000
Fz static [N]	1700
Mx static [Nm]	67
My static [Nm]	90
Mz static [Nm]	120

Geometrical moments of inertia of aluminum profile

Elastic modulus [N/mm ²]	70000
Ix [mm ⁴]	679000
Iy [mm ⁴]	697000

Weight	
Additional Weight per 100 mm [kg]	0.62
Basic Weight [kg]	6.5
Values for Calculating Inertias	
Pulley Material	Steel
Pulley Diameter [mm]	25.46
Effective Pulley Width [mm]	82
Belt Weight [kg/m]	0.123
Standard Carriage Weight [kg]	3.13
No-load torque [Nm]	0.5
Friction Coefficient	0.01