

## ELVZ 125 WAC

Call 800-321-7800 or visit us online at [www.nookindustries.com](http://www.nookindustries.com) to configure and order your ELVZ 125 WAC today!

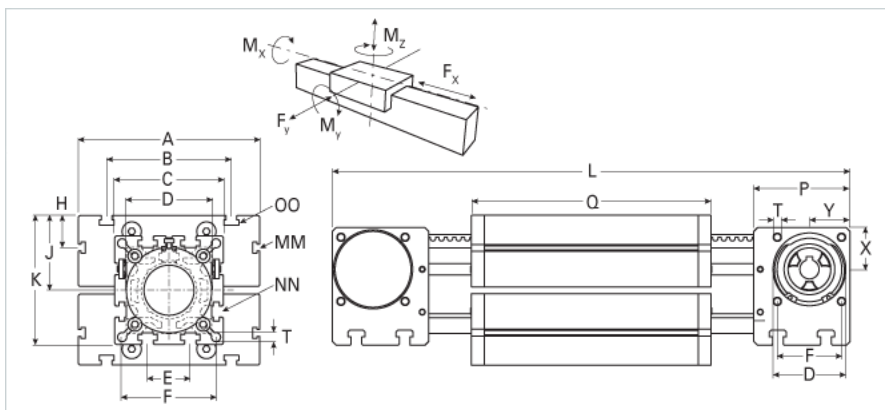
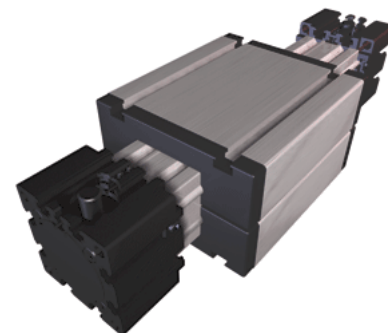

Details	
Size	125
Belt	8M50
mm/Rev	192
Number of Teeth	24
Dimensions	
Basic Length L [mm]	649
A [mm]	295
B [mm]	200
C [mm]	165
D [mm]	130x2
E [mm]	60
F [mm]	142
G [mm]	-
H [mm]	30
J [mm]	107.5
K [mm]	190
MM	M10
NN	M10
OO	M12
P [mm]	132
Q [mm]	389
T [mm]	13
U [mm]	58
V [mm]	90
W [mm]	35
X [mm]	60
Y [mm]	85
Z	M10
Shaft Diameter and Length [mm]	30 x 55
Key	8x7x40
Speed	
Speed Maximum [m/s]	6
Forces and Torques	
No-load torque [Nm]	1.6
Tensile force 0.2 sec [N]	5450
Tensile force permanent [N]	5000
Fx dynamic [N]	4950
Fy dynamic [N]	9000
Fz dynamic [N]	4500
Mx dynamic [Nm]	450
My dynamic [Nm]	600
Mz dynamic [Nm]	1150
Fx static [N]	5000
Fy static [N]	12000
Fz static [N]	6000
Mx static [Nm]	600
My static [Nm]	750
Mz static [Nm]	1350
Geometrical moments of inertia of aluminum profile	
Elastic modulus [N/mm <sup>2</sup> ]	70000
Ix [mm <sup>4</sup> ]	10150000
Iy [mm <sup>4</sup> ]	10150000
Weight	

Additional Weight per 100 mm [kg]	2.10
Basic Weight [kg]	37
<b>Values for Calculating Inertias</b>	
Pulley Material	Aluminum
Pulley Diameter [mm]	61.12
Effective Pulley Width [mm]	165
Belt Weight [kg/m]	0.480
Standard Carriage Weight [kg]	24.20
No-load torque [Nm]	1.6
Friction Coefficient	0.01