

ELHZ 60S

Call 800-321-7800 or visit us online at www.nookindustries.com to configure and order your ELHZ 60S today!

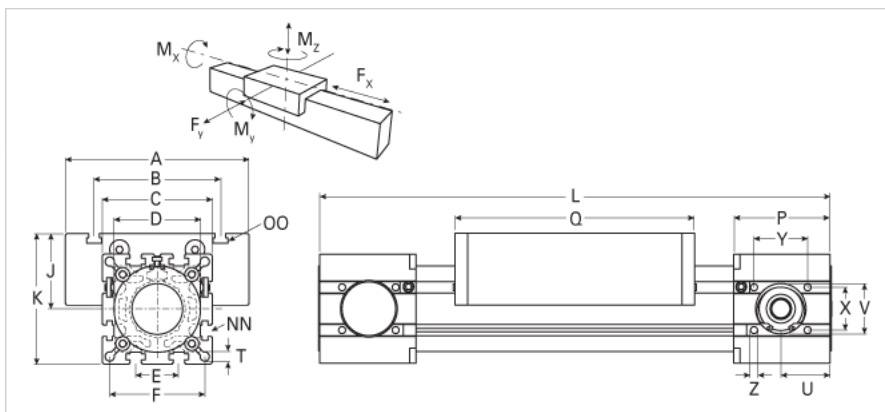
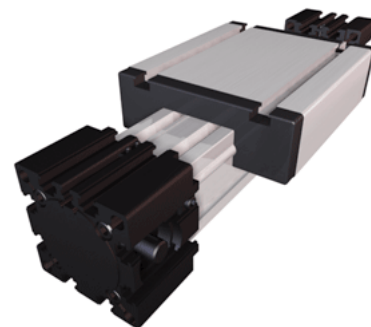

Details	
Size	60S
Belt	5M25
mm/Rev	80
Number of Teeth	16
Dimensions	
Basic Length L [mm]	315
A [mm]	170
B [mm]	108
C [mm]	82
D [mm]	62x1
E [mm]	30
F [mm]	69
G [mm]	-
H [mm]	-
J [mm]	49
K [mm]	94
MM	-
NN	M8
OO	M8
P [mm]	59
Q [mm]	194
T [mm]	8.5
U [mm]	23
V [mm]	37
W [mm]	14
X [mm]	30
Y [mm]	36
Z	M6
Shaft Diameter and Length [mm]	14 x 35
Key	5x5x28
Speed	
Speed Maximum [m/s]	4
Forces and Torques	
No-load torque [Nm]	0.5
Tensile force 0.2 sec [N]	800
Tensile force permanent [N]	700
Fx dynamic [N]	580
Fy dynamic [N]	3100
Fz dynamic [N]	1600
Mx dynamic [Nm]	65
My dynamic [Nm]	140
Mz dynamic [Nm]	170
Fx static [N]	700
Fy static [N]	4100
Fz static [N]	2160
Mx static [Nm]	88
My static [Nm]	190
Mz static [Nm]	230
Geometrical moments of inertia of aluminum profile	
Elastic modulus [N/mm ²]	70000
Ix [mm ⁴]	679000
Iy [mm ⁴]	697000
Weight	

Additional Weight per 100 mm [kg]	0.62
Basic Weight [kg]	5.8
Values for Calculating Inertias	
Pulley Material	Steel
Pulley Diameter [mm]	25.46
Effective Pulley Width [mm]	82
Belt Weight [kg/m]	0.123
Standard Carriage Weight [kg]	2.42
No-load torque [Nm]	0.5
Friction Coefficient	0.01