

## MLZ 80 WAC

Call 800-321-7800 or visit us online at [www.nookindustries.com](http://www.nookindustries.com) to configure and order your MLZ 80 WAC today!

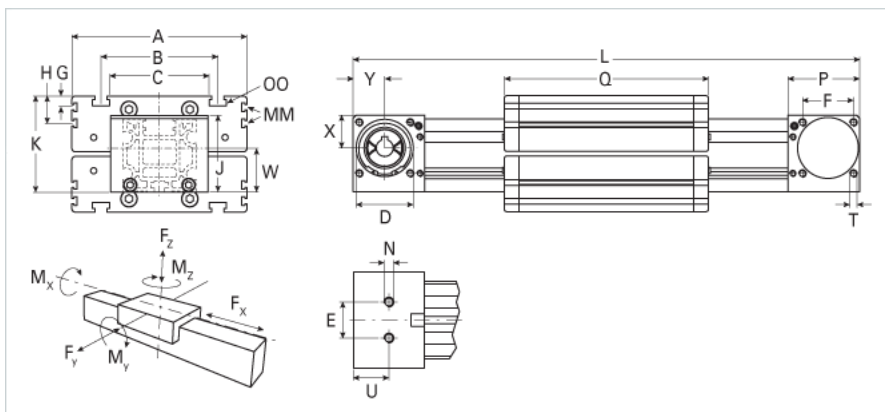
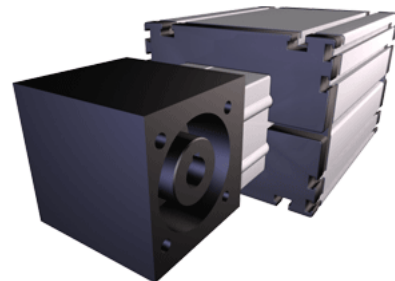

### Details

Size	80
Belt	8M30
mm/Rev	192
Number of Teeth	24

### Dimensions

Basic Length L [mm]	391
A [mm]	170
B [mm]	117
C [mm]	100
D [mm]	68
E [mm]	40
F [mm]	60
G [mm]	10
H [mm]	30
J [mm]	93
K [mm]	110
MM	M6
N	M10
OO	M10
P [mm]	90
Q [mm]	210
T	M8
U [mm]	47.5
W [mm]	40
X [mm]	45
Y [mm]	40
Shaft Diameter and Length [mm]	18 x 45
Key	6x6x40

### Speed

Speed Maximum [m/s]	6
---------------------	---

### Forces and Torques

No-load torque [Nm]	0.9
Tensile force 0.2 sec [N]	2090
Tensile force permanent [N]	1900
Fx dynamic [N]	1800
Fy dynamic [N]	2000
Fz dynamic [N]	1100
Mx dynamic [Nm]	55
My dynamic [Nm]	80
Mz dynamic [Nm]	120
Fx static [N]	1900
Fy static [N]	3000
Fz static [N]	1700
Mx static [Nm]	90
My static [Nm]	110
Mz static [Nm]	150

### Geometrical moments of inertia of aluminum profile

Elastic modulus [N/mm <sup>2</sup> ]	70000
Ix [mm <sup>4</sup> ]	1749000
Iy [mm <sup>4</sup> ]	1802000

### Weight

Additional Weight per 100 mm [kg]	1.00
Basic Weight [kg]	9.6

**Values for Calculating Inertias**

Pulley Material	Steel
Pulley Diameter [mm]	56.02
Effective Pulley Width [mm]	100
Belt Weight [kg/m]	0.256
Standard Carriage Weight [kg]	5.29
No-load torque [Nm]	0.9
Friction Coefficient	0.01