

ELZU 80S X-Axis WAC

Call 800-321-7800 or visit us online at www.nookindustries.com to configure and order your ELZU 80S X-Axis WAC today!

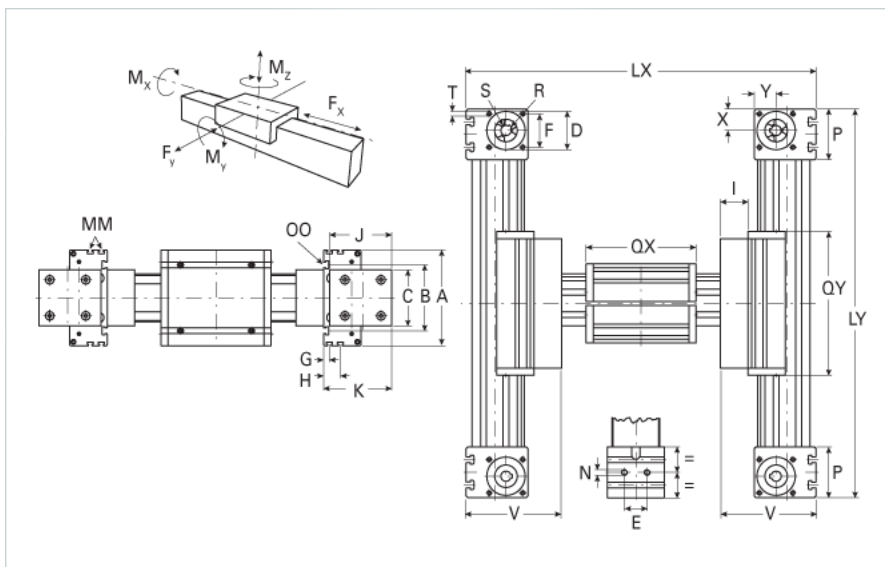
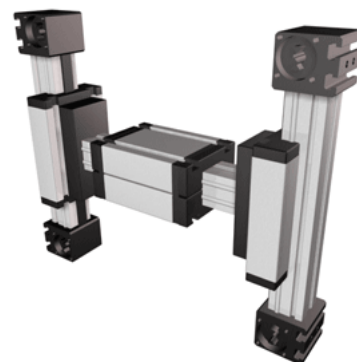

Details

Size	80S
Belt	8M30
mm/Rev	192
Number of Teeth	24

Dimensions

Basic length Lx [mm]	575
Basic length Ly [mm]	455
A [mm]	190
B [mm]	126
C [mm]	100
D [mm]	68
E [mm]	40
F [mm]	60
G [mm]	12.5
H [mm]	30
I [mm]	44
J [mm]	110
K [mm]	122
MM	M6
N	M10
OO	M10
P [mm]	90
Qx [mm]	234
Qy [mm]	264
T	M8
V [mm]	167
X [mm]	39
Y [mm]	38
Shaft Diameter and Length [mm]	18 x 45
Key	6x6x40

Speed

Speed Maximum [m/s]	6
---------------------	---

Forces and Torques

No-load torque [Nm]	1.8
Tensile force 0.2 sec [N]	2090
Tensile force permanent [N]	1900
Fx dynamic [N]	1800
Fy dynamic [N]	3600
Fz dynamic [N]	1800
Mx dynamic [Nm]	140
My dynamic [Nm]	230
Mz dynamic [Nm]	220
Fx static [N]	1900
Fy static [N]	4600
Fz static [N]	3000
Mx static [Nm]	170
My static [Nm]	270

Mz static [Nm]	300
Geometrical moments of inertia of aluminum profile	
Elastic modulus [N/mm ²]	70000
Ix [mm ⁴]	1899000
Iy [mm ⁴]	1897000
Weight	
Additional Weight per 100 mm [kg]	1.00
Basic Weight [kg]	32.0
Values for Calculating Inertias	
Pulley Material	Steel
Pulley Diameter [mm]	61.12
Effective Pulley Width [mm]	100.0
Belt Weight [kg/m]	0.256
Standard Carriage Weight X Axis [kg]	7.04
Standard Carriage Weight Y Axis [kg]	3.52
No-load torque [Nm]	1.2
Friction Coefficient	0.01