

## ELZU 60S X-Axis WAC

Call 800-321-7800 or visit us online at [www.nookindustries.com](http://www.nookindustries.com) to configure and order your ELZU 60S X-Axis WAC today!

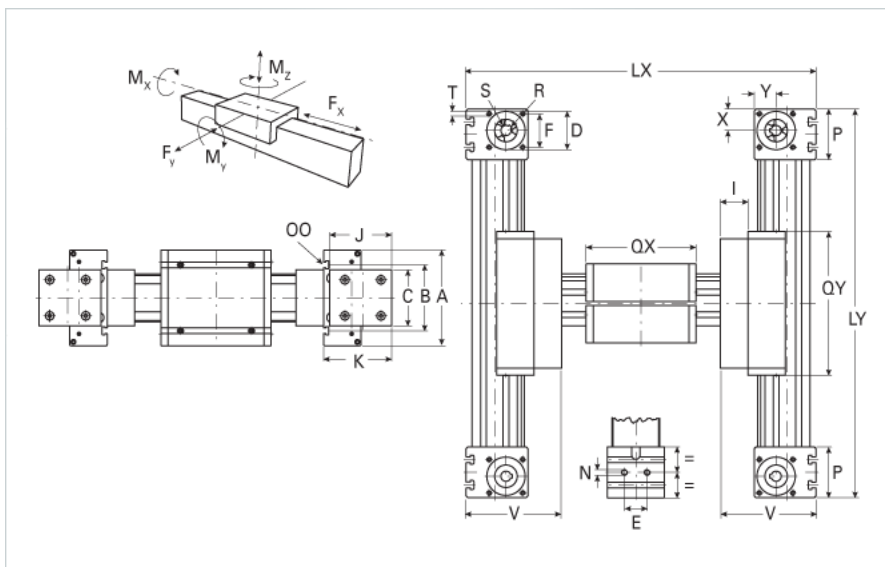
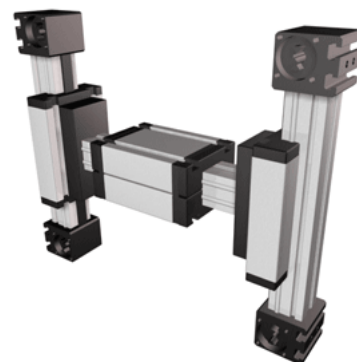

### Details

Size	60S
Belt	5M25
mm/Rev	130
Number of Teeth	26

### Dimensions

Basic length Lx [mm]	468
Basic length Ly [mm]	330
A [mm]	170
B [mm]	108
C [mm]	80
D [mm]	47
E [mm]	30
F [mm]	42
G [mm]	-
H [mm]	-
I [mm]	33
J [mm]	82
K [mm]	94
MM	-
N	M8
OO	M8
P [mm]	59
Qx [mm]	214
Qy [mm]	210
T	M6
V [mm]	127
X [mm]	26
Y [mm]	26
Shaft Diameter and Length [mm]	14 x 35
Key	5x5x28

### Speed

Speed Maximum [m/s]	5
---------------------	---

### Forces and Torques

No-load torque [Nm]	1.2
Tensile force 0.2 sec [N]	1000
Tensile force permanent [N]	900
Fx dynamic [N]	800
Fy dynamic [N]	3100
Fz dynamic [N]	1600
Mx dynamic [Nm]	65
My dynamic [Nm]	140
Mz dynamic [Nm]	170
Fx static [N]	894
Fy static [N]	4100
Fz static [N]	2160
Mx static [Nm]	88
My static [Nm]	190

Mz static [Nm]	230
<b>Geometrical moments of inertia of aluminum profile</b>	
Elastic modulus [N/mm <sup>2</sup> ]	70000
Ix [mm <sup>4</sup> ]	679000
Iy [mm <sup>4</sup> ]	697000
<b>Weight</b>	
Additional Weight per 100 mm [kg]	0.62
Basic Weight [kg]	17.7
<b>Values for Calculating Inertias</b>	
Pulley Material	Steel
Pulley Diameter [mm]	41.38
Effective Pulley Width [mm]	80.0
Belt Weight [kg/m]	0.123
Standard Carriage Weight X Axis [kg]	4.84
Standard Carriage Weight Y Axis [kg]	2.42
No-load torque [Nm]	0.7
Friction Coefficient	0.01