

## ELZT 100 Extended Carriage Standard Extension

Call 800-321-7800 or visit us online at [www.nookindustries.com](http://www.nookindustries.com) to configure and order your ELZT 100 Extended Carriage Standard Extension today!

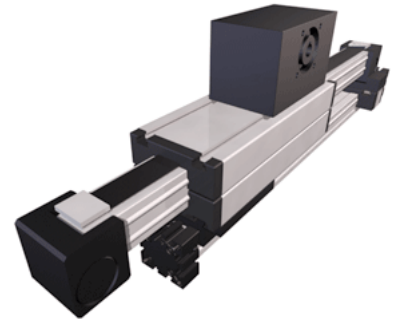
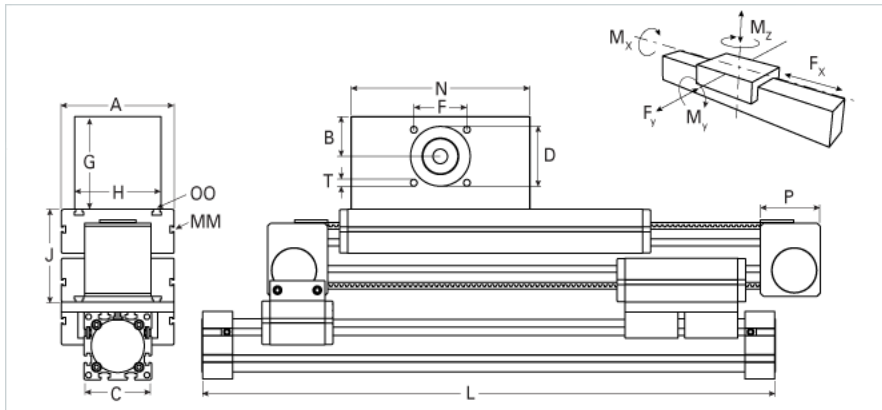

### Details

Size	100
Belt	8M100
mm/Rev	304
Number of Teeth	388
Pully Diameter [mm]	96.8

### Dimensions

Basic Length L [mm]	755
A [mm]	230
B [mm]	62
C [mm]	130
D [mm]	110
F [mm]	100
G [mm]	143
H [mm]	160
I [mm]	30
J [mm]	178
MM	M10
N [mm]	310
OO	M10
P [mm]	110
Q [mm]	575
T	M10
V [mm]	-
Shaft Diameter and Length [mm]	30 x 55
Key	8x7x40

### Speed

Speed Maximum [m/s]	8
---------------------	---

### Forces and Torques

No-load torque [Nm]	2.4
Tensile force 0.2 sec [N]	4300
Tensile force permanent [N]	4000
Fy dynamic [N]	6500
Fx dynamic [N]	3500
Fz dynamic [N]	2200
Mx dynamic [Nm]	230
My dynamic [Nm]	270
Mz dynamic [Nm]	500
Fx static [N]	4000
Fy static [N]	8000
Fz static [N]	3600
Mx static [Nm]	300
My static [Nm]	400
Mz static [Nm]	750

### Geometrical moments of inertia of aluminum profile

Elastic modulus [N/mm <sup>2</sup> ]	70000
Ix [mm <sup>4</sup> ]	4440000
Iy [mm <sup>4</sup> ]	4480000

### Weight

Additional Weight per 100 mm [kg]	1.95
Basic Weight [kg]	40.6