

ELZT 60 Extended Carriage Standard Extension

Call 800-321-7800 or visit us online at www.nookindustries.com to configure and order your ELZT 60 Extended Carriage Standard Extension today!

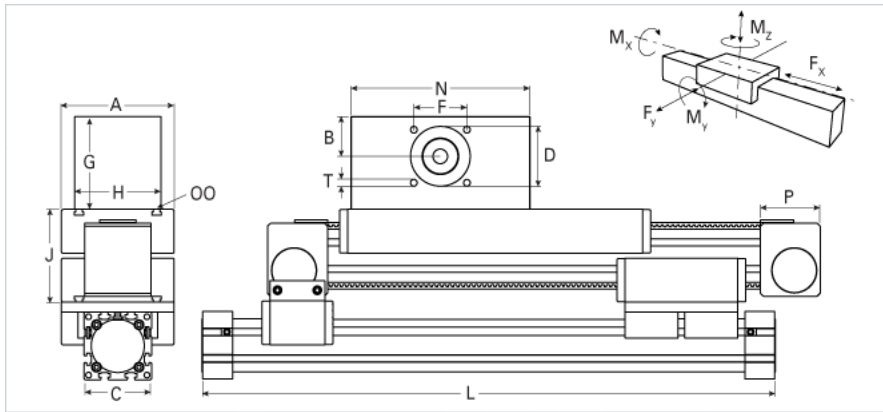
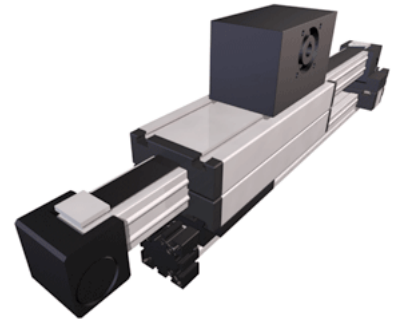

Details	
Size	60
Belt	8M30
mm/Rev	192
Number of Teeth	24
Pully Diameter [mm]	61.1
Dimensions	
Basic Length L [mm]	480
A [mm]	144
B [mm]	39
C [mm]	80
D [mm]	68
F [mm]	60
G [mm]	105
H [mm]	100
I [mm]	-
J [mm]	98
MM	-
N [mm]	180
OO	M8
P [mm]	59
Q [mm]	353
T	M8
V [mm]	-
Shaft Diameter and Length [mm]	18 x 45
Key	6x6x40
Speed	
Speed Maximum [m/s]	5
Forces and Torques	
No-load torque [Nm]	1.1
Tensile force 0.2 sec [N]	700
Tensile force permanent [N]	580
Fy dynamic [N]	2000
Fx dynamic [N]	470
Fz dynamic [N]	1100
Mx dynamic [Nm]	43
My dynamic [Nm]	70
Mz dynamic [Nm]	100
Fx static [N]	580
Fy static [N]	3000
Fz static [N]	1700
Mx static [Nm]	67
My static [Nm]	90
Mz static [Nm]	120
Geometrical moments of inertia of aluminum profile	
Elastic modulus [N/mm ²]	70000
Ix [mm ⁴]	679000
Iy [mm ⁴]	697000
Weight	
Additional Weight per 100 mm [kg]	0.73
Basic Weight [kg]	9.1