

ELSD 100 Extended Carriage

Call 800-321-7800 or visit us online at www.nookindustries.com to configure and order your ELSD 100 Extended Carriage today!

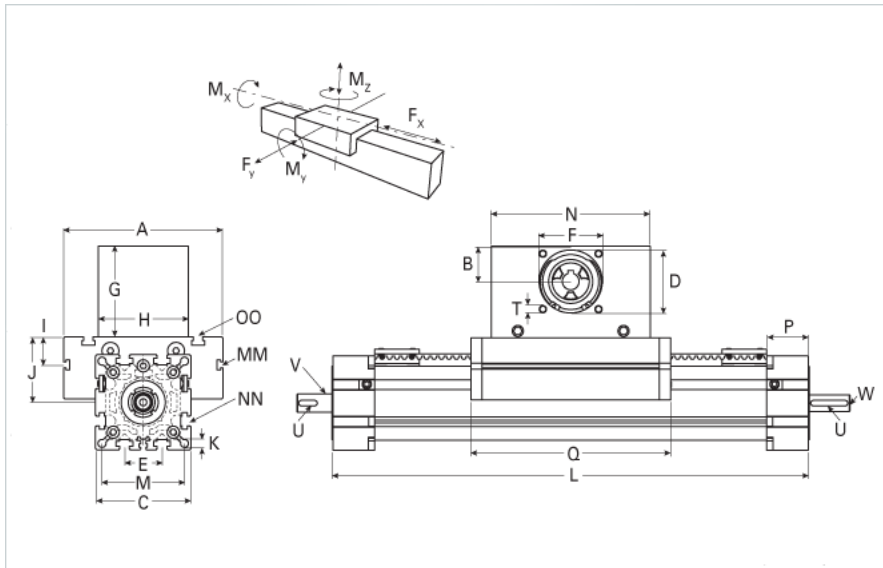
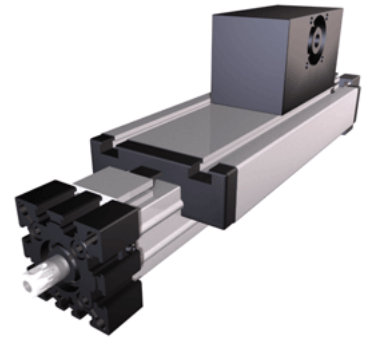

Details

Size	100
Belt	8M50
mm/Rev	256
Number of Teeth	32

Dimensions

Basic Length L [mm]	745
A [mm]	230
B [mm]	60
C [mm]	130
D [mm]	90
E [mm]	50
F [mm]	80
G [mm]	130
H [mm]	130
I [mm]	29
J [mm]	89
K [mm]	10.5
M [mm]	112
MM	M10
N [mm]	270
NN	M10
OO	M10
P [mm]	55
Q [mm]	535
T	M10
X [mm]	-
V (Z Drive End) [mm]	22 x 35
U (Z Drive End) [mm]	6x6x30
V (Z Load End) [mm]	25 x 35
U (Z Load End) [mm]	8x7x30
W (Z Load End) [mm]	M12x25
Shaft Diameter and Length [mm]	22 x 45
Key	6x6x40

Speed

Speed Maximum [m/s]	8
---------------------	---

Forces and Torques

No-load torque Stiction torque Mr [Nm]	0.1
No-load torque [Nm]	1.5
Tensile force 0.2 sec [N]	4300
Tensile force permanent [N]	4000
Fd [N]	400
Mr [Nm]	30
Fx dynamic [N]	3800
Fy dynamic [N]	6500
Fz dynamic [N]	2200
Mx dynamic [Nm]	230
My dynamic [Nm]	270

Mz dynamic [Nm]	500
Fx static [N]	4000
Fy static [N]	8000
Fz static [N]	3600
Mx static [Nm]	300
My static [Nm]	400
Mz static [Nm]	750
Geometrical moments of inertia of aluminum profile	
Elastic modulus [N/mm ²]	70000
Ix [mm ⁴]	4440000
Iy [mm ⁴]	4480000
Weight	
Additional Weight per 100 mm [kg]	1.70
Basic Weight [kg]	27.0
Values for Calculating Inertias	
Pulley Material - Drive Pulley (x1)	Aluminum
Pulley Material - Idler Pulleys (x2)	Aluminum
Pulley Diameter [mm]	81.49
Effective Pulley Width [mm]	130
Belt Weight [kg/m]	0.355
Standard Carriage Weight [kg]	12.72
No-load torque [Nm]	1.5
Friction Coefficient	0.01