

ELSZ 80 WAC Extended Carriage

Call 800-321-7800 or visit us online at www.nookindustries.com to configure and order your ELSZ 80 WAC Extended Carriage today!

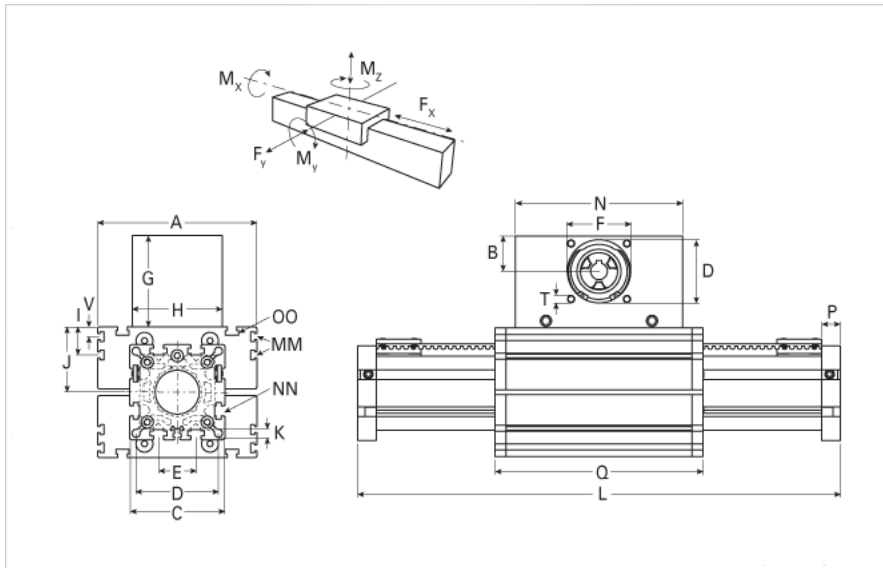
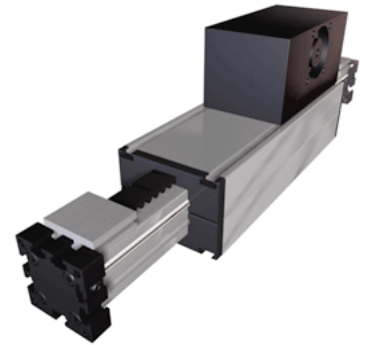

Details

Size	80
Belt	8M30
mm/Rev	192
Number of Teeth	24

Dimensions

Basic Length L [mm]	541
A [mm]	170
B [mm]	39
C [mm]	102
D [mm]	68
E [mm]	40
F [mm]	60
G [mm]	100
H [mm]	100
I [mm]	30
J [mm]	70
K [mm]	8.5
MM	M6
N [mm]	180
NN	M10
O [mm]	88
OO	M10
P [mm]	20
Q [mm]	395
T	M8
V [mm]	10
Shaft Diameter and Length [mm]	18 x 45
Key	6x6x40

Speed

Speed Maximum [m/s]	6
---------------------	---

Forces and Torques

No-load torque [Nm]	1.1
Tensile force 0.2 sec [N]	2090
Tensile force permanent [N]	1900
Fx dynamic [N]	1800
Fy dynamic [N]	2000
Fz dynamic [N]	1100
Mx dynamic [Nm]	55
My dynamic [Nm]	80
Mz dynamic [Nm]	120
Fx static [N]	1900
Fy static [N]	3000
Fz static [N]	1700
Mx static [Nm]	90
My static [Nm]	110
Mz static [Nm]	150

Geometrical moments of inertia of aluminum profile

Elastic modulus [N/mm ²]	70000
Ix [mm ⁴]	1899000
Iy [mm ⁴]	1897000
Weight	
Additional Weight per 100 mm [kg]	1.00
Basic Weight [kg]	11.0
Values for Calculating Inertias	
Pulley Material - Drive Pulley (x1)	Steel
Pulley Material - Idler Pulleys (x2)	Aluminum
Pulley Diameter [mm]	61.12
Effective Pulley Width [mm]	102
Belt Weight [kg/m]	0.256
Standard Carriage Weight [kg]	10.98
No-load torque [Nm]	1.1
Friction Coefficient	0.01