

ELZ 60S Dual Carriage

Call 800-321-7800 or visit us online at www.nookindustries.com to configure and order your ELZ 60S Dual Carriage today!

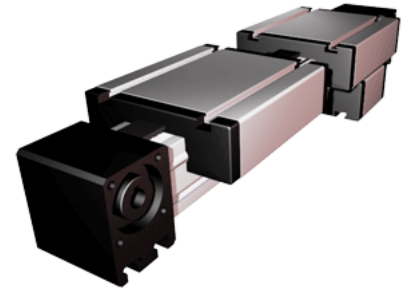
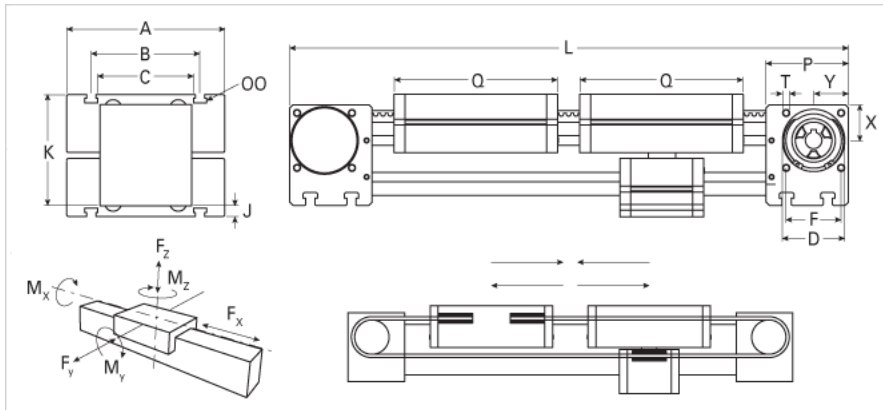

Details

Size	60S
Belt	5M25
mm/Rev	130
Number of Teeth	26

Dimensions

Basic Length L [mm]	510
A [mm]	170
B [mm]	108
C [mm]	80
D [mm]	47
F [mm]	42
G [mm]	-
H [mm]	-
J [mm]	12
K [mm]	106
MM	-
OO	M8
P [mm]	59
Q [mm]	194
T	M6
X [mm]	27
Y [mm]	27
Shaft Diameter and Length [mm]	14 x 35
Key	5x5x28

Speed

Speed Maximum [m/s]	7
---------------------	---

Forces and Torques

No-load torque [Nm]	0.7
Tensile force 0.2 sec [N]	1000
Tensile force permanent [N]	900
Fx dynamic [N]	800
Fy dynamic [N]	3100
Fz dynamic [N]	1600
Mx dynamic [Nm]	65
My dynamic [Nm]	140
Mz dynamic [Nm]	170
Fx static [N]	894
Fy static [N]	4100
Fz static [N]	2160
Mx static [Nm]	88
My static [Nm]	190
Mz static [Nm]	230

Geometrical moments of inertia of aluminum profile

Elastic modulus [N/mm ²]	70000
Ix [mm ⁴]	679000
Iy [mm ⁴]	697000

Weight

Additional Weight per 100 mm [kg]	0.62
Basic Weight [kg]	7.4

Values for Calculating Inertias

Pulley Material	Steel
Pulley Diameter [mm]	41.38
Effective Pulley Width [mm]	80

Belt Weight [kg/m]	0.123
Standard Carriage Weight [kg]	2.42
No-load torque [Nm]	0.7
Friction Coefficient	0.01