

ELZ 125 WAC

Call 800-321-7800 or visit us online at www.nookindustries.com to configure and order your ELZ 125 WAC today!

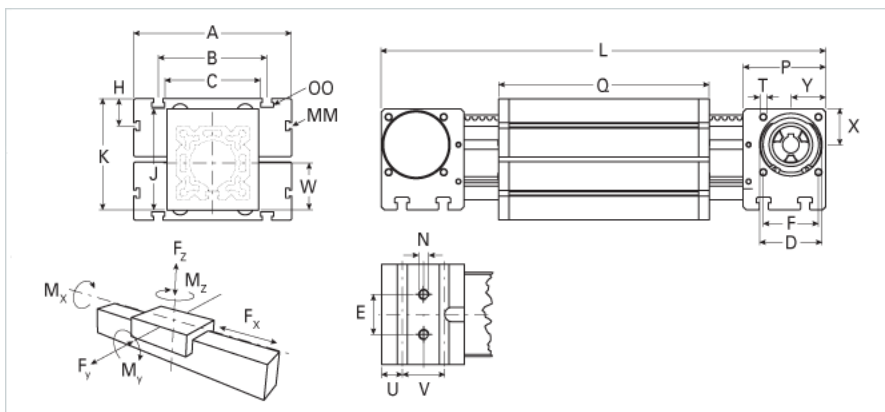
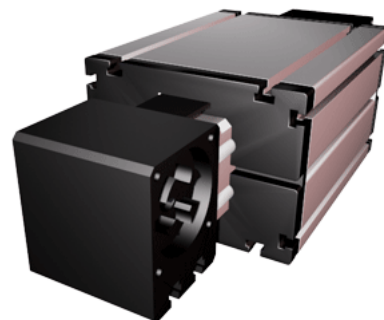

Details	
Size	125
Belt	8M70
mm/Rev	304
Number of Teeth	38
Dimensions	
Basic Length L [mm]	649
A [mm]	295
B [mm]	200
C [mm]	160
D [mm]	110
E [mm]	60
F [mm]	100
G [mm]	-
H [mm]	30
J [mm]	167
K [mm]	191
MM T-Nut	M10
N - Bolt Size	M12
OO - T-Nut	M12
P [mm]	130
Q [mm]	389
T T-Nut	M10
U [mm]	40
V [mm]	50
W [mm]	82
X [mm]	60
Y [mm]	60
Shaft Diameter and Length [mm]	30 x 55
Key	8x7x50
Speed	
Speed Maximum [m/s]	10
Forces and Torques	
No-load torque [Nm]	1.8
Tensile force 0.2 sec [N]	6350
Tensile force permanent [N]	5900
Fx dynamic [N]	5750
Fy dynamic [N]	9000
Fz dynamic [N]	4500
Mx dynamic [Nm]	450
My dynamic [Nm]	600
Mz dynamic [Nm]	1150
Fx static [N]	5900
Fy static [N]	12000
Fz static [N]	6000
Mx static [Nm]	600
My static [Nm]	750
Mz static [Nm]	1350
Geometrical moments of inertia of aluminum profile	
Elastic modulus [N/mm ²]	70000
Ix [mm ⁴]	10150000
Iy [mm ⁴]	10150000
Weight	
Additional Weight per 100 mm [kg]	2.10

Basic Weight [kg]	37.0
Values for Calculating Inertias	
Pulley Material	Aluminum
Pulley Diameter [mm]	96.77
Effective Pulley Width [mm]	160.0
Belt Weight [kg/m]	0.480
Standard Carriage Weight [kg]	24.20
No-load torque [Nm]	1.8
Friction Coefficient	0.01