

## UL 60 Compact Carriage

Call 800-321-7800 or visit us online at [www.nookindustries.com](http://www.nookindustries.com) to configure and order your UL 60 Compact Carriage today!

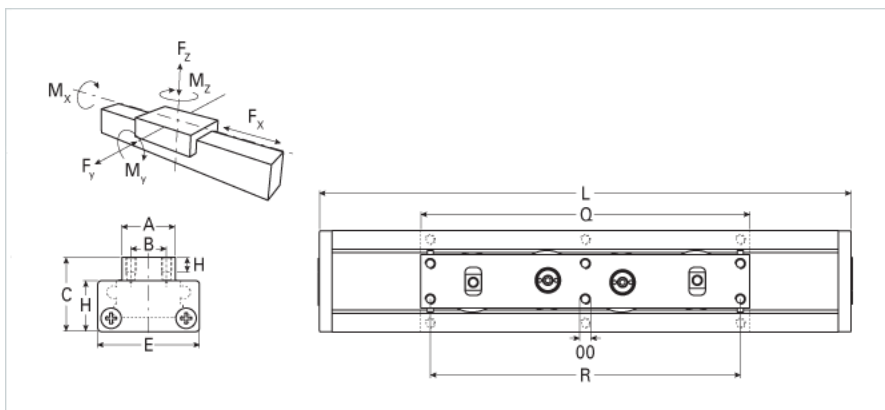
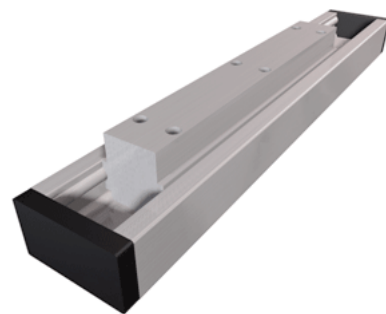

Details	
Size	60
Dimensions	
A [mm]	29
B [mm]	20
C [mm]	43
E [mm]	60
H [mm]	30
Basic Length L [mm]	215
OO	M6x10
P [mm]	8
Q [mm]	194
R [mm]	180
S [mm]	7.5
T [mm]	11.0
Speed	
Speed Maximum [m/s]	5
Forces and Torques	
Fx dynamic [N]	-
Fy dynamic [N]	2000
Fz dynamic [N]	1100
Mx dynamic [N]	43
My dynamic [N]	70
Mz dynamic [N]	100
Fx static [N]	-
Fy static [N]	3000
Fz static [N]	1700
Mx static [N]	67
My static [N]	93
Mz static [N]	120
Geometrical moments of inertia of aluminum profile	
Elastic modulus [N/mm <sup>2</sup> ]	70000
Ix [mm <sup>4</sup> ]	171000
Iy [mm <sup>4</sup> ]	610000
Weight	
Additional Weight per 100 mm [kg]	0.20
Basic Weight [kg]	2.1