

## ELK 30 WAC Dual Carriage

Call 800-321-7800 or visit us online at [www.nookindustries.com](http://www.nookindustries.com) to configure and order your ELK 30 WAC Dual Carriage today!

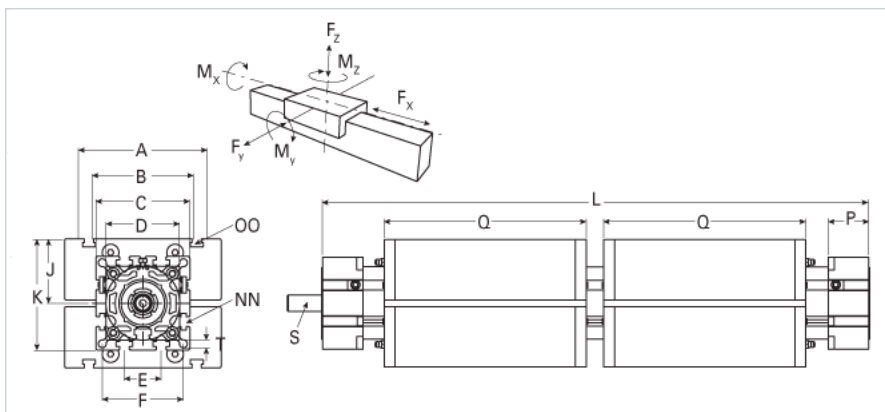
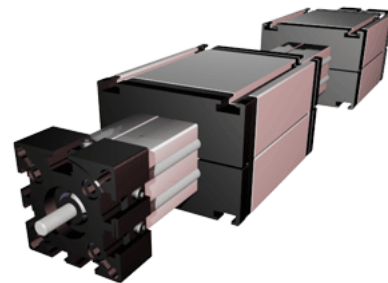

### Details

Size	30
Screw Options	8x2.5
Screw Type	Ball Screw

### Dimensions

Basic Length L [mm]	226
A [mm]	70
B [mm]	56
C [mm]	42
D [mm]	40x1
E [mm]	13
F [mm]	35
G [mm]	-
H [mm]	-
J [mm]	26
K [mm]	47
MM	-
NN	M6
OO	M6
P [mm]	18
Q [mm]	94
R [mm]	-
S Diameter x Length [mm]	5 x 15
T-Diameter [mm]	4.2

### Forces and Torques

No-load torque [Nm]	0.3
Fx dynamic [N]	600
Fy dynamic [N]	60
Fz dynamic [N]	60
Mx dynamic [Nm]	10
My dynamic [Nm]	10
Mz dynamic [Nm]	12
Fx static [N]	750
Fy static [N]	90
Fz static [N]	90
Mx static [Nm]	12
My static [Nm]	12
Mz static [Nm]	15

### Geometrical moments of inertia of aluminum profile

Elastic modulus [N/mm <sup>2</sup> ]	70000
Ix [mm <sup>4</sup> ]	40900
Iy [mm <sup>4</sup> ]	40900

### Weight

Additional Weight per 100 mm [kg]	0.16
Basic Weight [kg]	1.1