

## EGK 30 WAC

Call 800-321-7800 or visit us online at [www.nookindustries.com](http://www.nookindustries.com) to configure and order your EGK 30 WAC today!

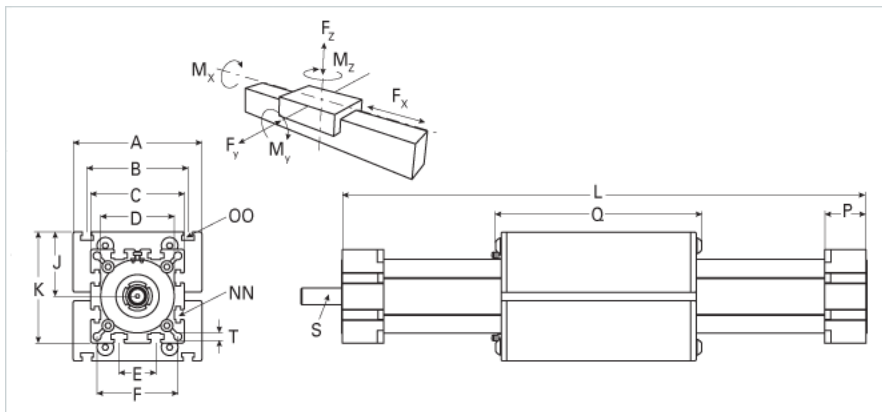
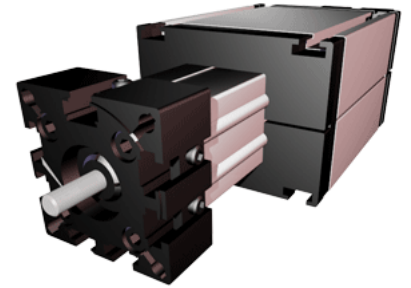

Details	
Size	30
Screw Options	8x2.5
Screw Type	Ball Screw
Dimensions	
Basic Length L [mm]	120
A [mm]	70
B [mm]	56
C [mm]	42
D [mm]	40x1
E [mm]	13
F [mm]	35
H [mm]	-
J [mm]	26
K [mm]	47
MM [mm]	-
NN [mm]	M6
OO [mm]	M6
P [mm]	18
Q [mm]	82
R [mm]	3x3x25
S Diameter x Length [mm]	5x16
T-Diameter [mm]	4.2
Forces and Torques	
No Load Torque [Nm]	0.25
Fx dynamic [N]	600
Fy dynamic [N]	60
Fz dynamic [N]	60
Mx dynamic [Nm]	5
My dynamic [Nm]	6
Mz dynamic [Nm]	7
Fx static [N]	750
Fy static [N]	90
Fz static [N]	90
Mx static [Nm]	10
My static [Nm]	13
Mz static [Nm]	14
Geometrical moments of inertia of aluminum profile	
Elastic modulus [N/mm <sup>2</sup> ]	70000
Ix [mm <sup>4</sup> ]	40900
Iy [mm <sup>4</sup> ]	40000
Weight	
Additional Weight per 100 mm [kg]	0.16
Basic Weight [kg]	0.6