

EGT 40 WAC Dual Carriage

Call 800-321-7800 or visit us online at www.nookindustries.com to configure and order your EGT 40 WAC Dual Carriage today!

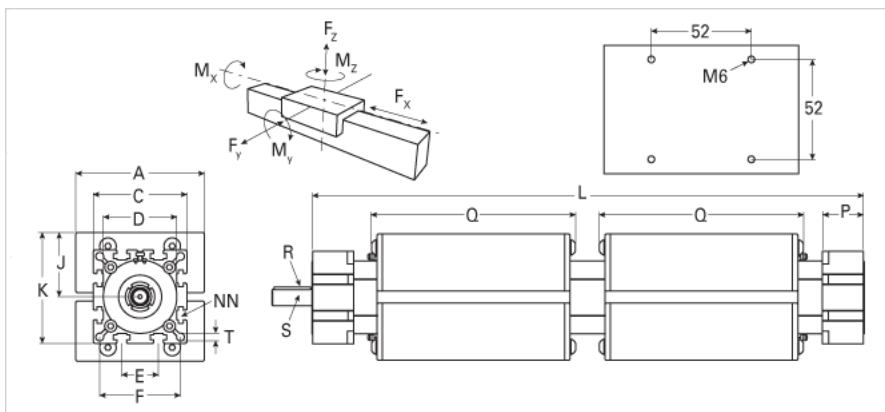
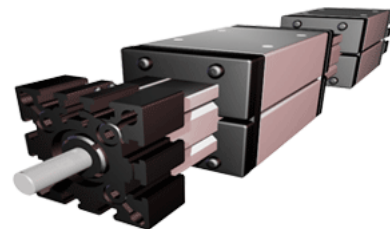

Details	
Size	40
Screw Options	18x4/18x8
Screw Type	Trapezoidal
Dimensions	
Basic Length L [mm]	318
A [mm]	70
B [mm]	-
C [mm]	58
D [mm]	48x1
E [mm]	18
F [mm]	47
H [mm]	-
J [mm]	35
K [mm]	64
MM [mm]	-
NN [mm]	M6
OO [mm]	M6
P [mm]	25
Q [mm]	133
R [mm]	3x3x25
S Diameter x Length [mm]	10x27
T-Diameter [mm]	6.5
Forces and Torques	
No Load Torque [Nm]	0.7
Fx dynamic [N]	1200
Fy dynamic [N]	315
Fz dynamic [N]	450
Mx dynamic [Nm]	18
My dynamic [Nm]	40
Mz dynamic [Nm]	30
Fx static [N]	1500
Fy static [N]	350
Fz static [N]	500
Mx static [Nm]	20
My static [Nm]	44
Mz static [Nm]	33
Geometrical moments of inertia of aluminum profile	
Elastic modulus [N/mm ²]	70000
Ix [mm ⁴]	135000
Iy [mm ⁴]	148000
Weight	
Additional Weight per 100 mm [kg]	0.36
Basic Weight [kg]	1.3