

## ELFZ 60S

Call 800-321-7800 or visit us online at [www.nookindustries.com](http://www.nookindustries.com) to configure and order your ELFZ 60S today!

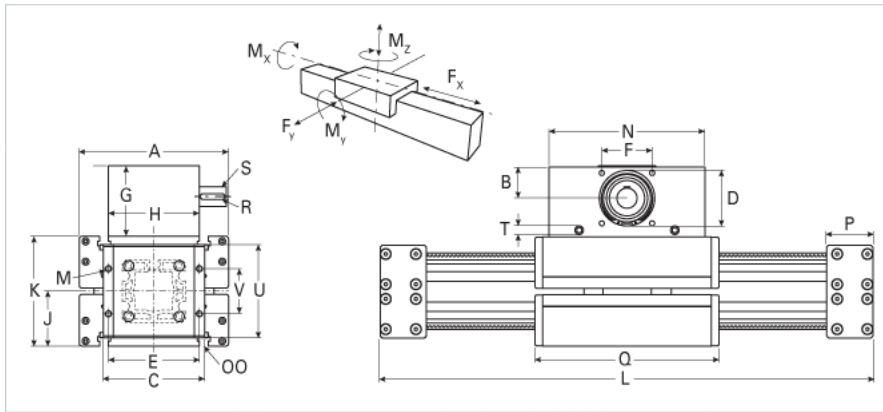
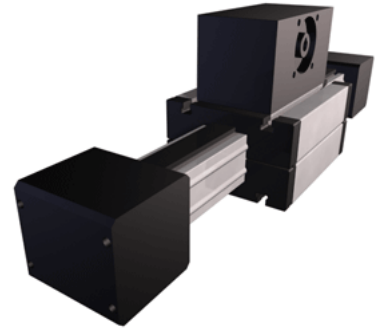

### Details

Size	60S
Belt	8M30
mm/Rev	96
Number of Teeth	24

### Dimensions

Basic Length L [mm]	410
A [mm]	170
B [mm]	38
C [mm]	108
D [mm]	68
E [mm]	97
F [mm]	60
G [mm]	102
H [mm]	100
I [mm]	
J [mm]	53
K [mm]	106
M	M8
MM	
N [mm]	180
OO [mm]	M8
P [mm]	97
Q [mm]	214
R [mm]	6x6x40
S [mm]	18x45
T	M8
U [mm]	97
V [mm]	60
Shaft Diameter and Length [mm]	18 x 45
Key	6x6x40

### Speed

Speed Maximum [m/s]	4
---------------------	---

### Forces and Torques

Drive Torque Maximum [Nm]	48
No-load torque [Nm]	1.3
Mz dynamic [Nm]	340
Mz static [Nm]	460
Fx dynamic [N]	3200
Fy dynamic [N]	6200
Fz dynamic [N]	3200
Mx dynamic [Nm]	130
My dynamic [Nm]	280
Fx static [N]	3600
Fy static [N]	6200
Fz static [N]	3200
Mx static [Nm]	176
My static [Nm]	380

### Geometrical moments of inertia of aluminum profile

Elastic modulus [N/mm <sup>2</sup> ]	70000
Ix [mm <sup>4</sup> ]	679000
Iy [mm <sup>4</sup> ]	697000

### Weight

Additional Weight per 100 mm [kg]	0.64
-----------------------------------	------

Basic Weight [kg]	23.1
<b>Values for Calculating Inertias</b>	
Pulley Material - Drive Pulley (x5)	Steel
Pulley Material - Idler Pulleys (x2)	Plastic
Pulley Diameter [mm]	61.12
Effective Pulley Width [mm]	100
Belt Weight [kg/m]	0.123
Standard Carriage Weight [kg]	6.34
No-load torque [Nm]	1.3
Friction Coefficient	0.01