

## NH45LER Assembly

Call 800-321-7800 or visit us online at [www.nookindustries.com](http://www.nookindustries.com) to configure and order your NH45LER Assembly today!

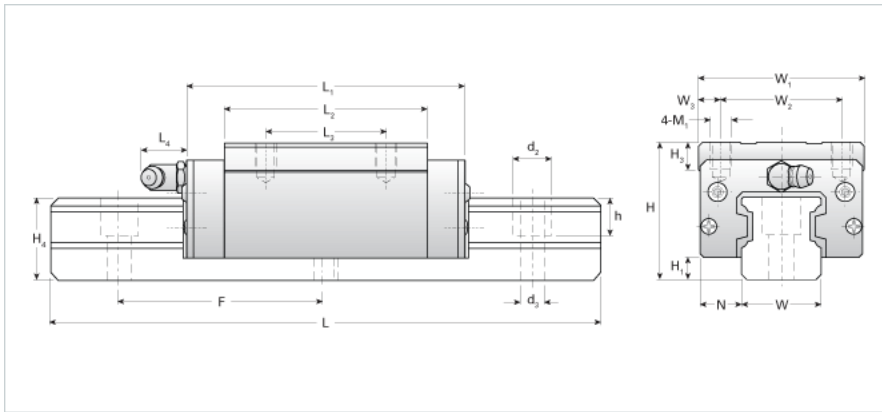

<b>Dimensions</b>	
H [mm]	70
H1 [mm]	11
N [mm]	20.5
<b>Metric Profile Rail (Rail)Details</b>	
Size [mm]	45
Type	Standard
<b>(Rail)Dimensions</b>	
d2 [mm]	20
d3 [mm]	14
h [mm]	21
H4 [mm]	42
F [mm]	105
W [mm]	45
Maximum Length [mm]	3000
<b>(Rail)Weight</b>	
Weights-Rail [kg/m]	12.9
<b>Metric Runner Block, Ultra Heavy Load, Narrow Width, 4 Tapped Holes (Runner Block)Details</b>	
Size [mm]	45
<b>(Runner Block)Dimensions</b>	
L1 [mm]	167
L2 [mm]	130
L3 [mm]	80
L4 [mm]	16
M1 x l	M10x17
H3 [mm]	15
W1 [mm]	86
W2 [mm]	60
W3 [mm]	13
<b>(Runner Block)Forces and Torques</b>	
Basic Load Ratings C [kN]	80.61
Basic Load Ratings C [lbf]	18116
Basic Load Ratings C0 [kN]	127.48
Basic Load Ratings C0 [lbf]	28651
Static Moment Ratings-Ma [kN-m]	2.11
Static Moment Ratings-Ma [lb-in]	18662
Static Moment Ratings-Mb [kN-m]	2.11
Static Moment Ratings-Mb [lb-in]	18662
Static Moment Ratings-Mc [kN-m]	3.13
Static Moment Ratings-Mc [lb-in]	27689
<b>(Runner Block)Weight</b>	
Weight-Block [kg]	3.70
<b>(Runner Block)Grease Fitting</b>	
Grease Fitting Part Number	B-PT 1/8