

## NH15TR Assembly

Call 800-321-7800 or visit us online at [www.nookindustries.com](http://www.nookindustries.com) to configure and order your NH15TR Assembly today!

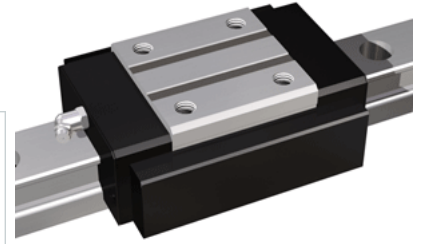
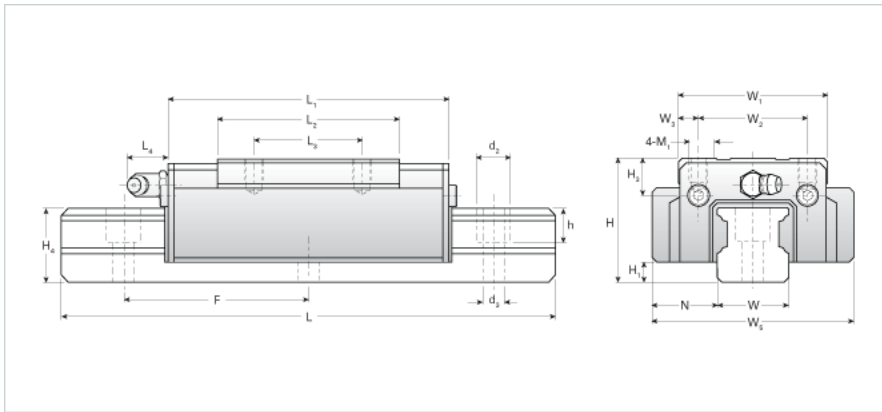

<b>Dimensions</b>	
H [mm]	28
H1 [mm]	4.6
N [mm]	9.5
<b>Metric Profile Rail (Rail)Details</b>	
Size [mm]	15
Type	Standard
<b>(Rail)Dimensions</b>	
d2 [mm]	7.5
d3 [mm]	4.5
h [mm]	7
H4 [mm]	17
F [mm]	60
W [mm]	15
Maximum Length [mm]	3000
<b>(Rail)Weight</b>	
Weights-Rail [kg/m]	1.7
<b>Metric Runner Block, Heavy Load, High Speed, 4 Tapped Holes On Runner Block (Runner Block)Details</b>	
Size [mm]	15
<b>(Runner Block)Dimensions</b>	
H3 [mm]	6
L1 [mm]	71
L2 [mm]	41
L3 [mm]	26
L4 [mm]	3
M1 x l	M4X5
W1 [mm]	34
W2 [mm]	26
W3 [mm]	4
W5 [mm]	48
<b>(Runner Block)Forces and Torques</b>	
Basic Load Ratings C [kN]	8.43
Basic Load Ratings C [lbf]	1895
Basic Load Ratings C0 [kN]	13.53
Basic Load Ratings C0 [lbf]	3041
Static Moment Ratings-Ma [kN-m]	0.07
Static Moment Ratings-Ma [lb-in]	608
Static Moment Ratings-Mb [kN-m]	0.07
Static Moment Ratings-Mb [lb-in]	608
Static Moment Ratings-Mc [kN-m]	0.13
Static Moment Ratings-Mc [lb-in]	1128
<b>(Runner Block)Weight</b>	
Weight-Block [kg]	0.19
<b>(Runner Block)Grease Fitting</b>	
Grease Fitting Part Number	PB1021B