

## NH15TB

Call 800-321-7800 or visit us online at [www.nookindustries.com](http://www.nookindustries.com) to configure and order your NH15TB today!

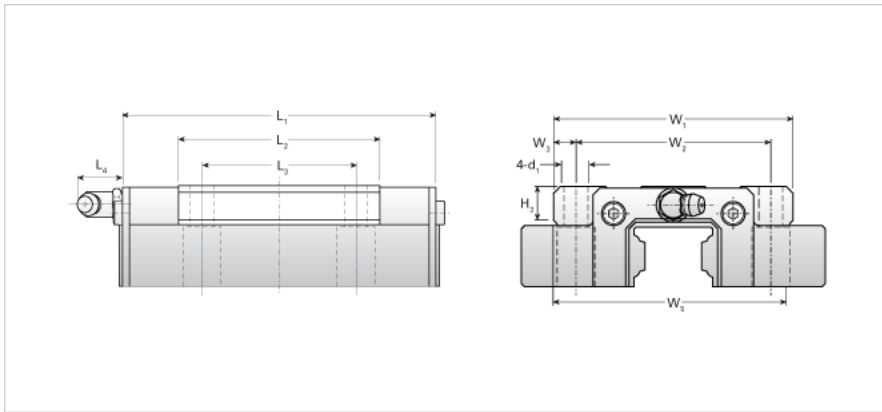
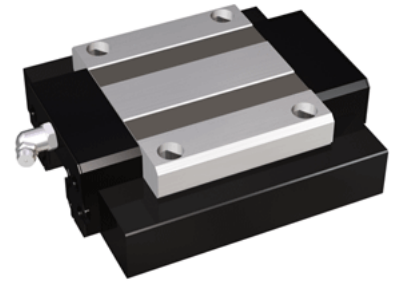

<b>Details</b>	
Size [mm]	15
<b>Dimensions</b>	
L1 [mm]	71
L2 [mm]	41
L3 [mm]	30
L4 [mm]	0
d1 x l	M4.5X7
H3 [mm]	5
W1 [mm]	47
W2 [mm]	38
W3 [mm]	4.5
W5 [mm]	60
<b>Forces and Torques</b>	
Basic Load Ratings C [kN]	8.43
Basic Load Ratings C [lbf]	1896
Basic Load Ratings C0 [kN]	13.53
Basic Load Ratings C0 [lbf]	3041
Static Moment Ratings-Ma [kN-m]	0.07
Static Moment Ratings-Ma [lb-in]	608
Static Moment Ratings-Mb [kN-m]	0.07
Static Moment Ratings-Mb [lb-in]	608
Static Moment Ratings-Mc [kN-m]	0.13
Static Moment Ratings-Mc [lb-in]	1128
<b>Weight</b>	
Weight-Block [kg]	0.21
<b>Grease Fitting</b>	
Grease Fitting Part Number	NAS516-1A