

QLZ 100

Call 800-321-7800 or visit us online at www.nookindustries.com to configure and order your QLZ 100 today!

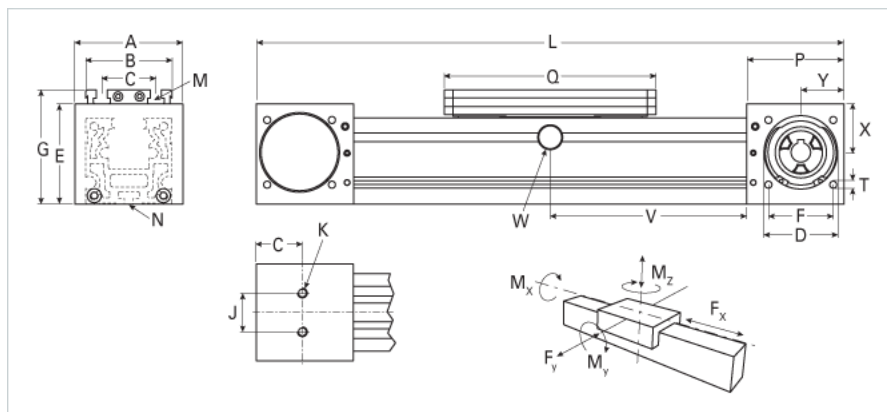
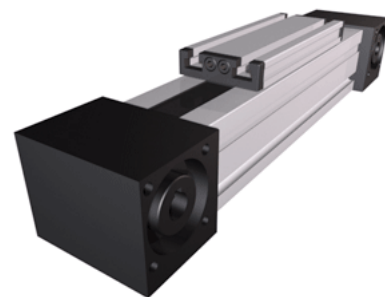

Details	
Size	100
Belt	8M50
mm/Rev	224
Number of Teeth	28
Dimensions	
Basic Length L [mm]	490
A [mm]	130
B [mm]	100
C [mm]	66
D [mm]	90
E [mm]	110
F [mm]	80
G [mm]	129
H [mm]	55
J [mm]	50
K	M12
M	M10
N	M10
P [mm]	110
Q [mm]	260
T	M10
X [mm]	49
Y [mm]	50
Shaft Diameter and Length [mm]	22 x 45
Key	6x6x40
Speed	
Speed Maximum [m/s]	7
Forces and Torques	
No-load torque [Nm]	1.2
Tensile force 0.2 sec [N]	4300
Tensile force permanent [N]	4000
F _x dynamic [N]	3800
F _y dynamic [N]	1500
F _z dynamic [N]	1700
M _x dynamic [Nm]	60
M _y dynamic [Nm]	110
M _z dynamic [Nm]	90
F _x static [N]	4000
F _y static [N]	1900
F _z static [N]	2100
M _x static [Nm]	85
M _y static [Nm]	140
M _z static [Nm]	110
Geometrical moments of inertia of aluminum profile	
Elastic modulus [N/mm ²]	70000
I _x [mm ⁴]	4300000
I _y [mm ⁴]	4880000
Shaft Details	
Key [mm]	6x6x40
Shaft Diameter h6 x Length [mm]	22 x 45
Weight	
Additional Weight per 100 mm [kg]	1.45
Basic Weight [kg]	15.8

Values for Calculating Inertias

Pulley Material	Aluminum
Pulley Diameter [mm]	71.30
Effective Pulley Width [mm]	130
Belt Weight [kg/m]	0.355
Standard Carriage Weight [kg]	2.92
No-load torque [Nm]	1.2
Friction Coefficient	0.01