

QSR 100

Call 800-321-7800 or visit us online at www.nookindustries.com to configure and order your QSR 100 today!

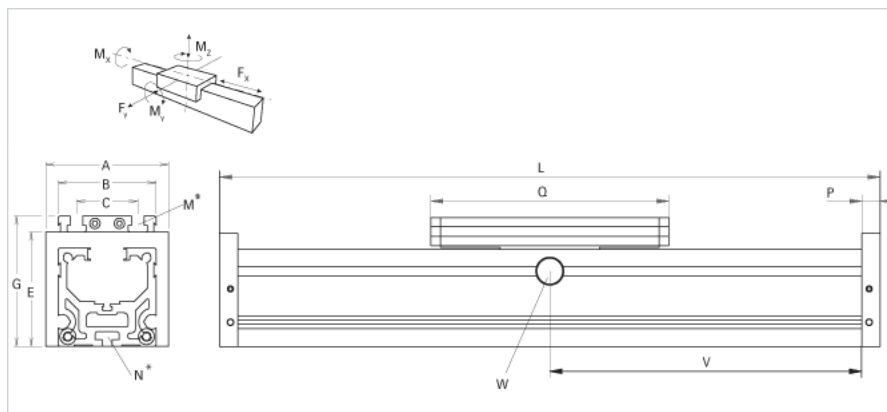

Details	
Size	100
Dimensions	
Basic Length L [mm]	315
A [mm]	130
B [mm]	100
C [mm]	66
E [mm]	110
G [mm]	129
M	M10
N	M10
P [mm]	20
Q [mm]	268
Speed	
Speed Maximum [m/s]	5
Forces and Torques	
F _x [N] 10000 km	-
F _y [N] 10000 km	2900
F _z [N] 10000 km	7270
M _x [Nm] 10000 km	101
M _y [Nm] 10000 km	311
M _z [Nm] 10000 km	292
F _x [N] 5000 km	-
F _y [N] 5000 km	7080
F _z [N] 5000 km	10300
M _x [Nm] 5000 km	142
M _y [Nm] 5000 km	439
M _z [Nm] 5000 km	412
Geometrical moments of inertia of aluminum profile	
Elastic modulus [N/mm ²]	70000
I _x [mm ⁴]	4300000
I _y [mm ⁴]	4880000
Weight	
Additional Weight per 100 mm [kg]	1.71
Basic Weight [kg]	8.2