

QSSZ 80

Call 800-321-7800 or visit us online at www.nookindustries.com to configure and order your QSSZ 80 today!

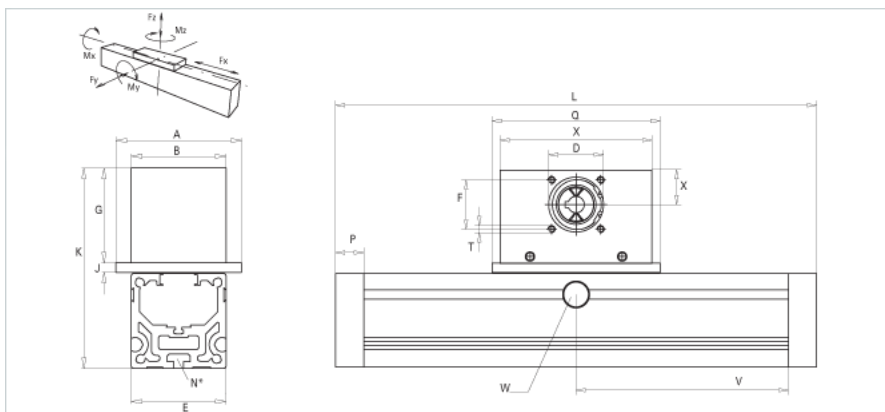
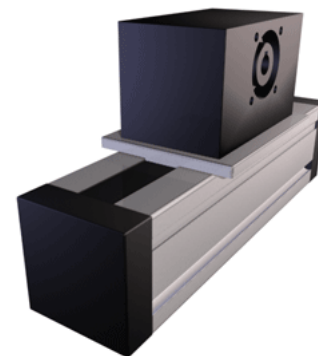

Details	
Size	80
Belt	5M25
mm/Rev	130
Number of Teeth	26
Pully Diameter [mm]	41.4
Dimensions	
Basic Length L [mm]	200
A [mm]	106
B [mm]	80
D [mm]	47
E [mm]	80
F [mm]	42
G [mm]	80
J [mm]	8
K [mm]	169
N	M6
P [mm]	24
Q [mm]	144
T	M6
X [mm]	130
Y [mm]	30
Shaft Diameter and Length [mm]	14 x 35
Key	5x5x28
Speed	
Speed Maximum [m/s]	5
Forces and Torques	
No-load torque [Nm]	1.4
Fx [N] 10000 km	800
Fy [N] 10000 km	450
Fz [N] 10000 km	3933
Mx [Nm] 10000 km	33
My [Nm] 10000 km	222
Mz [Nm] 10000 km	210
Fx [N] 5000 km	894
Fy [N] 5000 km	567
Fz [N] 5000 km	4955
Mx [Nm] 5000 km	41
My [Nm] 5000 km	310
Mz [Nm] 5000 km	296
Tensile force 0.2 sec [N]	1000
Tensile force permanent [N]	900
Geometrical moments of inertia of aluminum profile	
Elastic modulus [N/mm ²]	70000
Ix [mm ⁴]	1650000
Iy [mm ⁴]	1870000
Weight	
Additional Weight per 100 mm [kg]	1.02
Basic Weight [kg]	5.7