

DSZ 200

Call 800-321-7800 or visit us online at www.nookindustries.com to configure and order your DSZ 200 today!

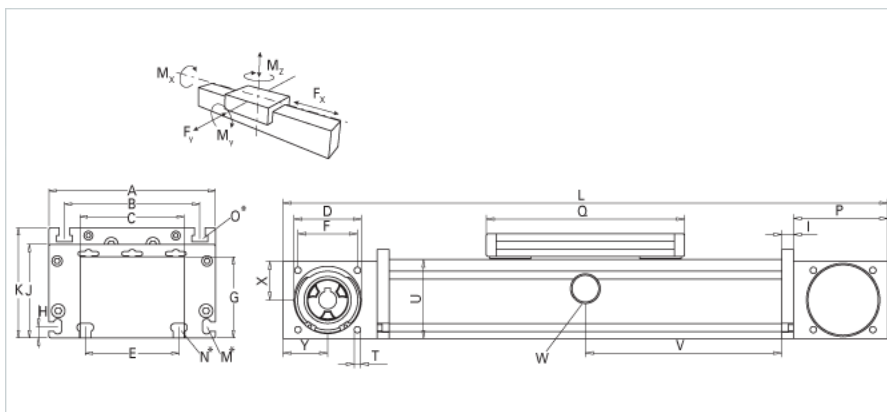
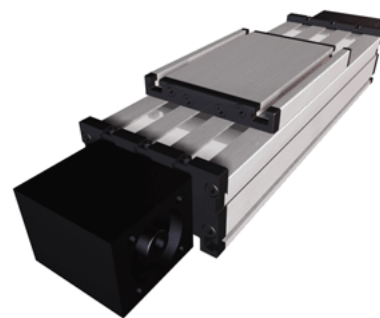

Details	
Size	200
Belt	8M50/8M70
mm/Rev	176/224
Number of Teeth	22/28
Dimensions	
Basic Length L [mm]	530
A [mm]	200
B [mm]	160
C [mm]	130
D [mm]	90
E [mm]	140
F [mm]	80
G [mm]	97
H [mm]	15
I [mm]	15
J [mm]	110
K [mm]	129
M	M8
N	M10
O	M10
P [mm]	110
Q [mm]	270
T	M10
U [mm]	100
X [mm]	49
Y [mm]	50
Speed	
Speed Maximum [m/s]	5
Forces and Torques	
No-load torque with cover bands	2.9
No-load torque without cover bands	2
F _x [N] 10000 km	3800
F _y [N] 10000 km	11080
F _z [N] 10000 km	14600
M _x [Nm] 10000 km	915
M _y [Nm] 10000 km	980
M _z [Nm] 10000 km	690
F _x [N] 5000 km	4000
F _y [N] 5000 km	15600
F _z [N] 5000 km	20600
M _x [Nm] 5000 km	1285
M _y [Nm] 5000 km	1375
M _z [Nm] 5000 km	1345
Tensile force 0.2 sec [N]	4300
Tensile force permanent [N]	4000
Geometrical moments of inertia of aluminum profile	
Elastic modulus [N/mm ²]	70000
I _x [mm ⁴]	4810000
I _y [mm ⁴]	26000000
Weight	
Additional Weight per 100 mm [kg]	2.90
Basic Weight [kg]	21.3
Values for Calculating Inertias	

Pulley Material	Aluminum
Pulley Diameter [mm]	71.30
Effective Pulley Width [mm]	130
Belt Weight [kg/m]	0.355
Standard Carriage Weight [kg]	5.35
No-load torque (w/cover bands) [Nm]	4.0
No-load torque (w/o cover bands) [Nm]	2.0
Friction Coefficient	0.01