

ELVZ 80S

Call 800-321-7800 or visit us online at www.nookindustries.com to configure and order your ELVZ 80S today!

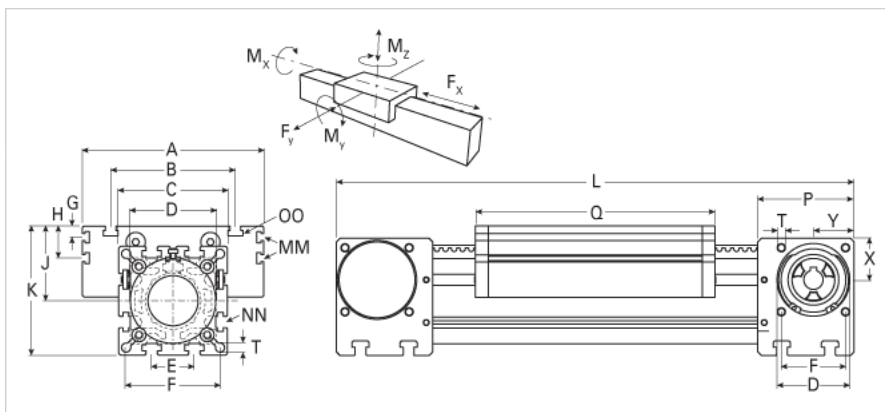
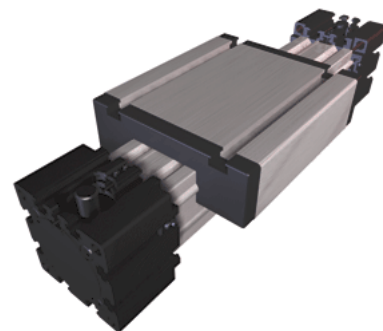

Details	
Size	80S
Belt	5M25
mm/Rev	110
Number of Teeth	22
Dimensions	
Basic Length L [mm]	395
A [mm]	190
B [mm]	126
C [mm]	102
D [mm]	80x1
E [mm]	40
F [mm]	88
G [mm]	12.5
H [mm]	30
J [mm]	71
K [mm]	122
MM	M6
NN	M10
OO	M8
P [mm]	90
Q [mm]	214
T [mm]	8.5
U [mm]	38
V [mm]	47
W [mm]	18
X [mm]	40
Y [mm]	50
Z	M8
Shaft Diameter and Length [mm]	18 x 45
Key	6x6x40
Speed	
Speed Maximum [m/s]	4
Forces and Torques	
No-load torque [Nm]	1.2
Tensile force 0.2 sec [N]	1150
Tensile force permanent [N]	100
Fx dynamic [N]	840
Fy dynamic [N]	3600
Fz dynamic [N]	1800
Mx dynamic [Nm]	140
My dynamic [Nm]	230
Mz dynamic [Nm]	200
Fx static [N]	1000
Fy static [N]	4600
Fz static [N]	3000
Mx static [Nm]	170
My static [Nm]	270
Mz static [Nm]	300
Geometrical moments of inertia of aluminum profile	
Elastic modulus [N/mm ²]	70000
Ix [mm ⁴]	1899000
Iy [mm ⁴]	1897000
Weight	

Additional Weight per 100 mm [kg]	1.00
Basic Weight [kg]	11
Values for Calculating Inertias	
Pulley Material	Steel
Pulley Diameter [mm]	35.01
Effective Pulley Width [mm]	102
Belt Weight [kg/m]	0.256
Standard Carriage Weight [kg]	3.52
No-load torque [Nm]	1.2
Friction Coefficient	0.01