

## ELVZ 80 Dual Carriage

Call 800-321-7800 or visit us online at [www.nookindustries.com](http://www.nookindustries.com) to configure and order your ELVZ 80 Dual Carriage today!

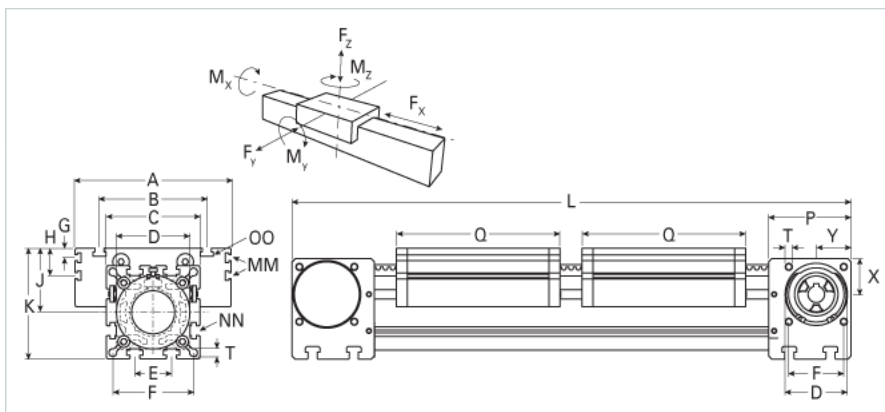
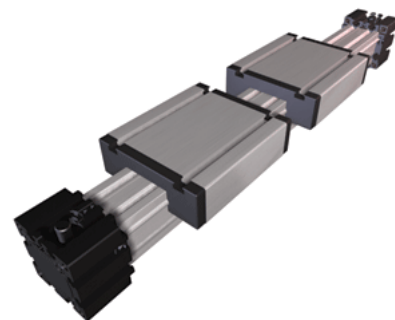

### Details

Size	80
Belt	5M25
mm/Rev	110
Number of Teeth	22

### Dimensions

Basic Length L [mm]	570
A [mm]	170
B [mm]	117
C [mm]	102
D [mm]	80x1
E [mm]	40
F [mm]	88
G [mm]	10
H [mm]	30
J [mm]	70
K [mm]	121
MM	M6
NN	M10
OO	M10
P [mm]	90
Q [mm]	194
T [mm]	8.5
U [mm]	38
V [mm]	47
W [mm]	18
X [mm]	40
Y [mm]	50
Z	M8
Shaft Diameter and Length [mm]	18 x 45
Key	6x6x40

### Speed

Speed Maximum [m/s]	4
---------------------	---

### Forces and Torques

No-load torque [Nm]	0.8
Tensile force 0.2 sec [N]	1150
Tensile force permanent [N]	1000
Fx dynamic [N]	840
Fy dynamic [N]	2000
Fz dynamic [N]	1100
Mx dynamic [Nm]	55
My dynamic [Nm]	80
Mz dynamic [Nm]	120
Fx static [N]	1000
Fy static [N]	3000
Fz static [N]	1700
Mx static [Nm]	90
My static [Nm]	110
Mz static [Nm]	150

### Geometrical moments of inertia of aluminum profile

Elastic modulus [N/mm <sup>2</sup> ]	70000
Ix [mm <sup>4</sup> ]	1899000
Iy [mm <sup>4</sup> ]	1897000

### Weight

Additional Weight per 100 mm [kg]	1.00
Basic Weight [kg]	13.0
<b>Values for Calculating Inertias</b>	
Pulley Material	Steel
Pulley Diameter [mm]	35.01
Effective Pulley Width [mm]	102
Belt Weight [kg/m]	0.256
Standard Carriage Weight [kg]	2.64
No-load torque [Nm]	0.8
Friction Coefficient	0.01