

## MLZ 100

Call 800-321-7800 or visit us online at [www.nookindustries.com](http://www.nookindustries.com) to configure and order your MLZ 100 today!

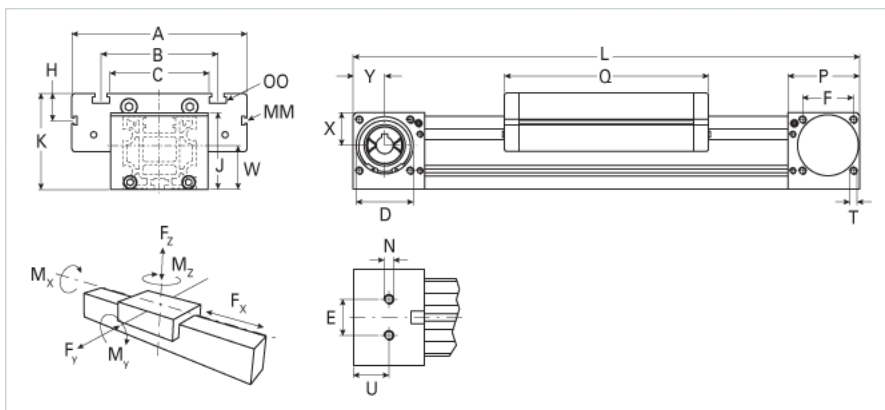
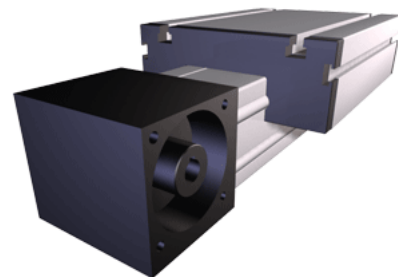

Details	
Size	100
Belt	8M50
mm/Rev	256
Number of Teeth	32
Dimensions	
Basic Length L [mm]	530
A [mm]	230
B [mm]	155
C [mm]	130
D [mm]	90
E [mm]	110
F [mm]	80
G [mm]	-
H [mm]	29
J [mm]	120
K [mm]	139
MM	M10
N	M12
OO	M10
P [mm]	110
Q [mm]	300
T	M10
U [mm]	55
W [mm]	50
X [mm]	49
Y [mm]	50
Shaft Diameter and Length [mm]	22 x 45
Key	6x6x40
Speed	
Speed Maximum [m/s]	10
Forces and Torques	
No-load torque [Nm]	1.4
Tensile force 0.2 sec [N]	4300
Tensile force permanent [N]	4000
Fx dynamic [N]	3800
Fy dynamic [N]	6500
Fz dynamic [N]	2200
Mx dynamic [Nm]	230
My dynamic [Nm]	270
Mz dynamic [Nm]	500
Fx static [N]	4000
Fy static [N]	8000
Fz static [N]	3600
Mx static [Nm]	300
My static [Nm]	400
Mz static [Nm]	750
Geometrical moments of inertia of aluminum profile	
Elastic modulus [N/mm <sup>2</sup> ]	70000
Ix [mm <sup>4</sup> ]	4350000
Iy [mm <sup>4</sup> ]	3940000
Weight	
Additional Weight per 100 mm [kg]	1.55
Basic Weight [kg]	22.5

**Values for Calculating Inertias**

Pulley Material	Aluminum
Pulley Diameter [mm]	71.30
Effective Pulley Width [mm]	130
Belt Weight [kg/m]	0.355
Standard Carriage Weight [kg]	6.55
No-load torque [Nm]	1.4
Friction Coefficient	0.01