

ELZ 80

Call 800-321-7800 or visit us online at www.nookindustries.com to configure and order your ELZ 80 today!

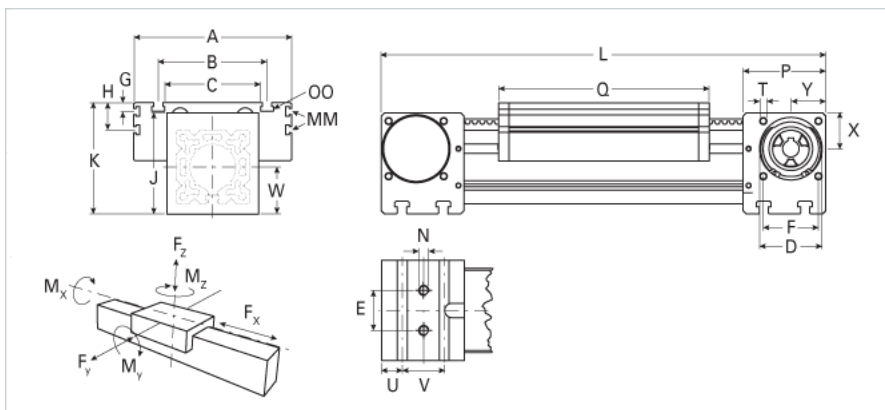
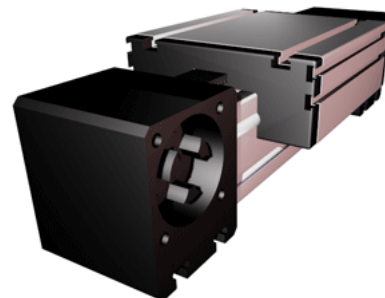

Details	
Size	80
Belt	8M30
mm/Rev	192
Number of Teeth	24
Dimensions	
Basic Length L [mm]	375
A [mm]	170
B [mm]	117
C [mm]	100
D [mm]	68
E [mm]	40
F [mm]	60
G [mm]	10
H [mm]	30
J [mm]	110
K [mm]	121
MM T-Nut	M6
N - Bolt Size	M10
OO - T-Nut	M10
P [mm]	90
Q [mm]	194
T T-Nut	M8
U [mm]	22.5
V [mm]	45
W [mm]	51
X [mm]	39
Y [mm]	38
Shaft Diameter and Length [mm]	18 x 45
Key	6x6x40
Speed	
Speed Maximum [m/s]	6
Forces and Torques	
Tensile force 0.2 sec [N]	2090
Tensile force permanent [N]	1900
Fx dynamic [N]	1800
Fy dynamic [N]	2000
Fz dynamic [N]	1100
Mx dynamic [Nm]	55
My dynamic [Nm]	80
Mz dynamic [Nm]	120
Fx static [N]	1900
Fy static [N]	3000
Fz static [N]	1700
Mx static [Nm]	90
My static [Nm]	110
Mz static [Nm]	150
Geometrical moments of inertia of aluminum profile	
Elastic modulus [N/mm ²]	70000
Ix [mm ⁴]	1899000
Iy [mm ⁴]	1897000
Weight	
Additional Weight per 100 mm [kg]	1.00
Basic Weight [kg]	10.0

Values for Calculating Inertias

Pulley Material	Steel
Pulley Diameter [mm]	61.12
Effective Pulley Width [mm]	100
Belt Weight [kg/m]	0.256
Standard Carriage Weight [kg]	2.64
No-load torque [Nm]	0.9
Friction Coefficient	0.01