

ELZ 125 Dual Carriage

Call 800-321-7800 or visit us online at www.nookindustries.com to configure and order your ELZ 125 Dual Carriage today!

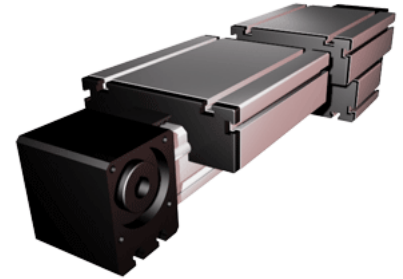
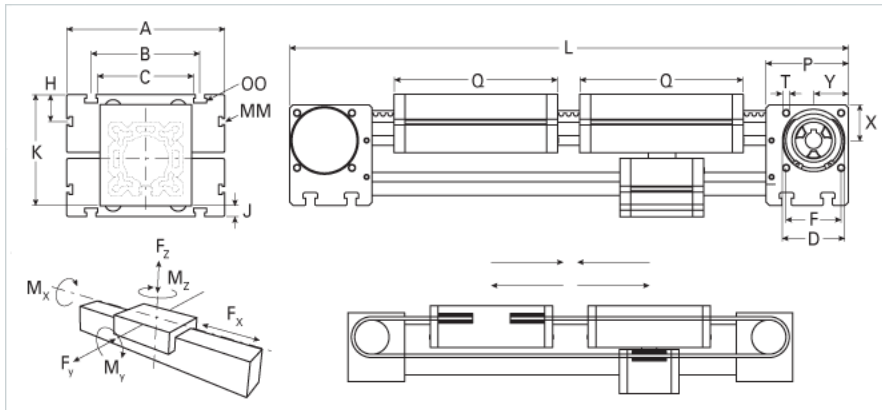

Details

Size	125
Belt	8M70
mm/Rev	304
Number of Teeth	38

Dimensions

Basic Length L [mm]	990
A [mm]	295
B [mm]	200
C [mm]	160
D [mm]	110
F [mm]	100
G [mm]	-
H [mm]	30
J [mm]	25.5
K [mm]	216
MM	M10
OO	M12
P [mm]	130
Q [mm]	365
T	M10
X [mm]	60
Y [mm]	60
Shaft Diameter and Length [mm]	30 x 55
Key	8x7x50

Speed

Speed Maximum [m/s]	10
---------------------	----

Forces and Torques

No-load torque [Nm]	1.4
Tensile force 0.2 sec [N]	4300
Tensile force permanent [N]	4000
Fx dynamic [N]	3800
Fy dynamic [N]	9000
Fz dynamic [N]	4500
Mx dynamic [Nm]	450
My dynamic [Nm]	600
Mz dynamic [Nm]	1150
Fx static [N]	5900
Fy static [N]	12000
Fz static [N]	6000
Mx static [Nm]	600
My static [Nm]	750
Mz static [Nm]	1350

Geometrical moments of inertia of aluminum profile

Elastic modulus [N/mm ²]	70000
Ix [mm ⁴]	10150000
Iy [mm ⁴]	10150000

Weight

Additional Weight per 100 mm [kg]	2.10
Basic Weight [kg]	53.5

Values for Calculating Inertias

Pulley Material	Aluminum
Pulley Diameter [mm]	96.77
Effective Pulley Width [mm]	160

Belt Weight [kg/m]	0.480
Standard Carriage Weight [kg]	12.10
No-load torque [Nm]	1.8
Friction Coefficient	0.01