

## ELZ 100 Dual Carriage

Call 800-321-7800 or visit us online at [www.nookindustries.com](http://www.nookindustries.com) to configure and order your ELZ 100 Dual Carriage today!

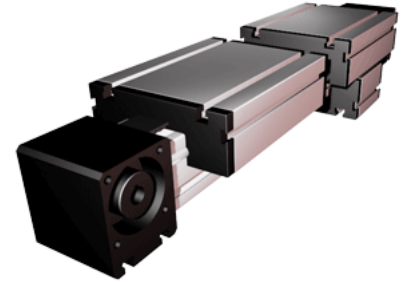
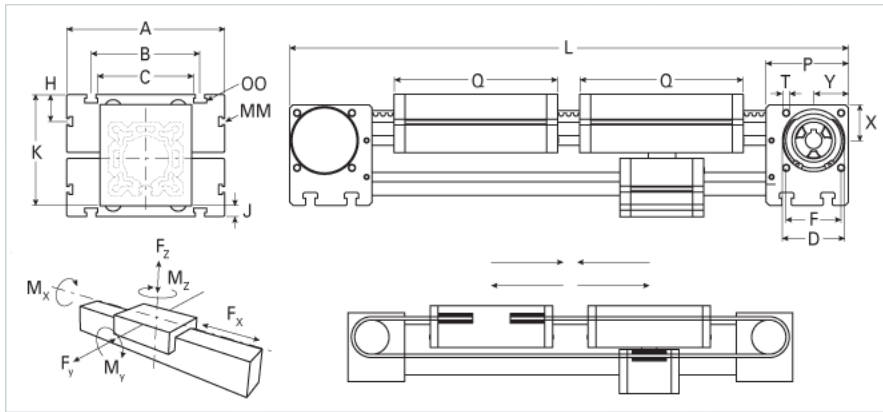

### Details

Size	100
Belt	8M50
mm/Rev	256
Number of Teeth	32

### Dimensions

Basic Length L [mm]	830
A [mm]	230
B [mm]	155
C [mm]	130
D [mm]	90
F [mm]	80
G [mm]	-
H [mm]	29
J [mm]	24
K [mm]	178
MM	M10
OO	M10
P [mm]	110
Q [mm]	300
T	M10
X [mm]	50
Y [mm]	50
Shaft Diameter and Length [mm]	22 x 45
Key	6x6x40

### Speed

Speed Maximum [m/s]	8
---------------------	---

### Forces and Torques

No-load torque [Nm]	1.2
Tensile force 0.2 sec [N]	2090
Tensile force permanent [N]	1900
Fx dynamic [N]	1800
Fy dynamic [N]	6500
Fz dynamic [N]	2200
Mx dynamic [Nm]	230
My dynamic [Nm]	270
Mz dynamic [Nm]	500
Fx static [N]	4000
Fy static [N]	8000
Fz static [N]	3600
Mx static [Nm]	300
My static [Nm]	400
Mz static [Nm]	750

### Geometrical moments of inertia of aluminum profile

Elastic modulus [N/mm <sup>2</sup> ]	70000
Ix [mm <sup>4</sup> ]	4440000
Iy [mm <sup>4</sup> ]	4480000

### Weight

Additional Weight per 100 mm [kg]	1.60
Basic Weight [kg]	34.0

### Values for Calculating Inertias

Pulley Material	Aluminum
Pulley Diameter [mm]	81.49
Effective Pulley Width [mm]	130

Belt Weight [kg/m]	0.355
Standard Carriage Weight [kg]	6.55
No-load torque [Nm]	1.4
Friction Coefficient	0.01