

Actionjac™

MACHINE SCREW JACKS

INSTALLATION, MAINTENANCE, & LUBRICATION INSTRUCTIONS

THIS ACTIONJAC™ MACHINE SCREW JACK WAS PROUDLY MADE IN THE USA BY THE EMPLOYEES OF NOOK INDUSTRIES, INC.

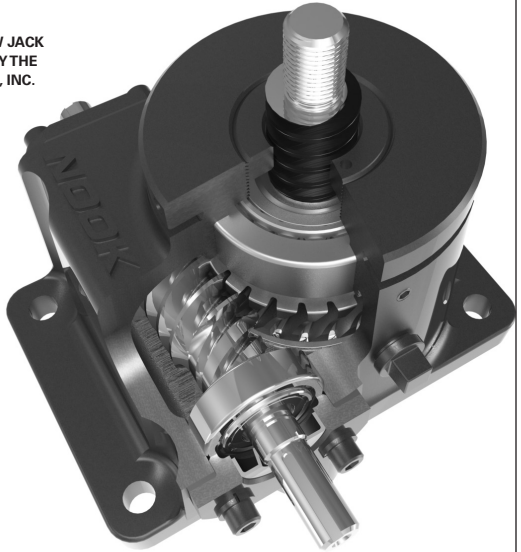

TABLE OF CONTENTS

| | |
|---|------|
| General instructions | 2 |
| Ordering Spare/Repair Parts | 2 |
| General Specifications | 3 |
| Lubrication | 3 |
| Installation Instructions..... | 4 |
| Tips for Disassembly & Reassembly | 5 |
| Disassembly Instructions | 5-8 |
| Exploded View of Jack Units..... | 6-7 |
| Reassembly | 8-9 |
| Troubleshooting | 9-10 |
| Anti-Backlash Adjustment..... | 11 |



CAUTION - The customer is responsible for providing stops at either end of travel. Machine Screw Jacks are usually self-locking. However, self-lowering or creep could result from vibratory conditions. In these cases, a brake should be considered. Overtravel could cause the lifting screw to become disengaged from the drive sleeve.

GENERAL INSTRUCTIONS

Your Machine Screw Jack is a high quality, sturdy unit designed to give many hours of trouble-free service. However, certain precautions and procedures must be observed in handling, installing and servicing the unit in order to obtain optimum performance.

1. Any apparent or suspected damage to equipment manufactured or furnished by Nook Industries during transport from the factory to the user should be immediately reported to both Nook Industries and the carrier.
2. Upon delivery all equipment furnished should be carefully inventoried against shipping papers to determine whether any shortages exist in delivered material. Any such shortages must immediately be reported to Nook Industries and the carrier.
3. The installation of most power transmission equipment does not normally require the services of a factory engineer. These services are not included in the selling price of the equipment unless specifically agreed upon in writing between the seller and purchaser. In applications requiring a more complex arrangement of components, consideration should be given to the use of a factory engineer for construction supervision or check-out of the installation. These services are available from Nook Industries by contacting the Service Department.

4. The Seller's warranty applies insofar as the unit is operated within the rating and service conditions for which it was specifically sold. The purchaser must prevent the existence of any destructive external conditions which might typically include vibratory loads due to critical speeds, severe shock loading, mechanical or thermal overloads, or side loads.
5. Adequate installation, maintenance and safety instructions must be given by the user to personnel directly responsible for the installation and operation of the equipment.
6. In the event of malfunction within the warranty period, the manufacturer must be informed promptly or, in any event, within thirty days if it is intended that the warranty is to cover the incident.

CAUTION - UNITS ARE NOT MEANT FOR PERSONNEL SUPPORT. Refer all applications for potential personnel support to the factory for approval.

ORDERING SPARE/REPAIR PARTS

This booklet contains general instructions, operating, maintenance and troubleshooting instructions for your ActionJac™ Worm Gear Jack. In the event spare or repair parts are required, call your local representative or contact Nook Industries at (216) 271-7900 or 1(800) 321-7800.

Please provide the following information when requesting spare/repair parts:

- Jack Size & Type Designation (i.e., 2 MSJ)
- Serial Number & Year of Manufacture (located on housing nameplate)
- Stroke Length
- Part Description (see pages 6-7)

GENERAL SPECIFICATIONS

The worm gear driven Machine Screw Jack incorporates an alloy steel worm which drives a high tensile bronze worm gear, accurately machined to the high standards of Nook Industries for maximum load carrying capacity and uniformity of motion transmission. All shafts are mounted on heavy duty, anti-friction bearings to increase operating efficiency of the drive mechanism. Thrust bearings are provided to support the rated thrust load of each unit. Housings are made of high strength material, well proportioned to handle the rated thrust and torque loads of each size unit.

CAUTION - In the absence of internal or external stops, it is possible to run the lifting screw out of the unit. Your Machine Screw Jack is NOT equipped with internal stops unless specifically requested in your order.

A lifting screw cover is threaded into the bottom of the unit on the upright model, or in the top of the unit on the inverted model, in order to keep the lifting screw threads free of foreign material.

Depending upon which jack model is purchased, the lifting screw is made of 4140 heat treated steel, 304 or 316 stainless steel, or a special alloy. The threads of the lifting screw for all models should be well lubricated and kept free of grit, dirt, or other abrasive contaminants. Fabric type protective boots, or spiral steel protectors, can be provided as an accessory to protect the exposed portion of the lifting screw. In the absence of positive stops, over-travel may crush protective boots.

CAUTION - Standard units should not be operated at input speeds over 1,800 RPM without consulting the factory. Machine Screw Jacks are designed for a maximum of two hours intermittent operation per day. For values higher than two hours per day, for any continuous operation, or for

repeated operation over any segment of total travel, consult factory.

LUBRICATION

The jack gearboxes are partially filled with a lubricant at the factory unless otherwise specified. Before operating any unit, verify lubricant presence. All jack housings are furnished with a grease fitting(s) and/or pipe plug(s).

Lubricant inspection is recommended at regular intervals. Once every six months is satisfactory under normal operating conditions, unless experience indicates that regreasing should occur at shorter or longer intervals. Severe operating conditions such as high duty cycles, high ambient temperatures, or contamination will shorten the lubrication inspection interval.

Lubricate internal jack components utilizing the grease fitting(s)/Port(s). When applying grease to the gearbox housing, sufficient grease pressure is required in order to properly apply grease to the bearing(s) and worm gear. When applied at the factory, lubricant is typically applied at 5,000psi. When utilizing an off-the-shelf, general-purpose grease gun or auto lubrication system, care must be taken to ensure proper amount of lubricant is dispensed.

Only a small amount of lubricant would be required. The below table is the amount of lubricant applied at the factory. When adding lubricant to the jack housing do not exceed the amount specified. See jack nameplate for specific lubricant installed in the gearbox, or consult factory.

The lubricant must not contain any grit or dirt, abrasives or fillers. It should not precipitate sediment, nor separate at temperatures up to 280°F. The lubricant must also have resistance to oxidation and must be non-channeling. For operating conditions outside these limits, consult factory.

Amount supplied at factory as follows:

| Jack capacity | Lube [oz.] |
|---------------|------------|
| MJ | 0.8 |
| 1 Ton | 1.6 |
| 2 Ton | 4 |
| 2 1/2 Ton | 4.5 |
| 5 Ton | 11 |
| 10 Ton | 14 |
| 15 Ton | 15 |
| 20 Ton | 24 |
| 30 Ton | 48 |
| 35 Ton | 48 |
| 50 Ton | 92 |
| 75 Ton | 144 |
| 100 Ton | 256 |

All units are suitable for intermittent operation providing that the housing temperature including ambient is not lower than -20°F or higher than +200°F. Factory supplied grease in standard units will operate in this range. Consult factory for available low-temperature greases when operating below -20°F.

Lifting screws should be checked periodically to insure they are adequately lubricated. This is especially necessary in rotating units where no lubrication is deposited on the lifting screw through the jack housing.

CAUTION - The user is responsible to insure lubricant compatibility. If improper lubricant is used or insufficient lubrication maintained, this will lead to degraded performance and failure.

INSTALLATION INSTRUCTIONS

1. Be certain that the rating of the jack exceeds the maximum load that may be imposed upon it.
2. The foundation for the unit must be rigid enough to maintain correct alignment with connected machinery

and have ample strength to carry the maximum load.

3. The foundation should have a flat mounting surface to uniformly support the jack unit. The opening for the lifting screw cover (or lifting screw) that passes through base must be as small as possible to provide jack support over the largest possible area.
4. It is extremely important that the jack be installed so that the lifting screw is exactly plumb and that all connecting shafting is aligned with the worm shaft.
5. After precise alignment, each member must be securely bolted and if possible, doweled in place. Doweling will assure exact repositioning if ever removed. It is essential that a jack unit be securely bolted down to its foundation using bolts of the proper diameter to fit mounting holes. Bolts should be S.A.E. Grade 5 or equivalent.

CAUTION - In the case of rotating units it is essential, for proper alignment and prevention of screw failure, that the load be attached to the traveling nut only when the load is in the position of travel closest to the jack housing

6. After the Jacks, mitre boxes, couplings, etc. are installed and aligned, there should be no signs of binding or misalignment.
7. Shaft coupling guards are the responsibility of the customer and are not provided unless specifically quoted to and ordered by the customer.
8. Caution must be taken when operating jack at either extreme of travel. If possible, hard external stops should be provided.

Torque values for bolting are as follows:

| Bolt Size (in) | Approx. Torque Value (ft-lb) |
|----------------|------------------------------|
| 1/4 | 6 |
| 3/8 | 20 |
| 1/2 | 50 |
| 5/8 | 100 |
| 3/4 | 165 |
| 7/8 | 265 |
| 1 | 400 |
| 1 1/4 | 830 |
| 1 1/2 | 1350 |
| 1 3/4 | 2500 |
| 2 | 3650 |

IMPORTANT - Take up evenly on mounting bolts to avoid damaging the housing.

9. If operating at the upper limits of the unit rating, DO NOT STOP the downward travel of the unit by running the lifting screw attachments or the load against the housing without checking with Nook Industries, as serious damage to the internal mechanism may result. The customer is responsible for providing mechanical stops and switches for control of the prime mover. None are included unless specifically quoted by and ordered from Nook Industries.

CAUTION - If limit switches are furnished by Nook Industries, they are NOT factory set. Limit switches should be set by carefully moving to the set position by hand or jogging. Care must be taken to avoid running lifting screws out of units or crushing boots.

TIPS FOR DISASSEMBLY AND REASSEMBLY

CAUTION - Disassembly of the actuator will void the warranty.

Never perform any work on the jack or as-

sociated transmission equipment (mitre boxes, couplings, etc.), until absolutely certain that the prime mover cannot be remotely or automatically started. Also make certain that load cannot affect personnel or machinery when the Jac, brake, or other holding devices are removed. Be sure disassembly area is relatively clean to prevent contamination of parts. Store all machined parts on wooden blocks or skids to prevent damage to machined surfaces.

Before starting disassembly, carefully review a typical parts list or certified assembly drawing of the unit.

When removing end caps, be sure to tape shaft extension keyways and other sharp edges to avoid damaging oil seals.

NOTES:

1. Be sure to clean and dry all parts before rebuilding.
2. It is advisable to replace old seals when the unit is rebuilt.
3. Remove any protective coatings on replacement parts before installing.

DISASSEMBLY INSTRUCTIONS 1 MSJ through 100 MSJ Models Only

Refer to typical parts, pages 6-7. No MJ models are serviceable in the field. These instructions are necessarily general, and as such, cannot provide for minor details of construction, which may vary from unit to unit. For specific questions, consult factory giving order number and serial number from unit name plate.

Upright or Inverted Units Disassembly

1. Unscrew lifting screw cover assembly from unit.
2. Remove protective boot and end attachment from lifting screw, if applicable.

ACTIONJAC™ MACHINE SCREW JACK

ALL MODELS 1-MSJ THROUGH 100-MSJ*

EXPLODED VIEW OF A TYPICAL ASSEMBLY

Views are illustrative only. See page 2 for ordering spare/repair parts.
 * Models M.J-20 through M.J-200 should not be disassembled. These units are not serviceable in the field.

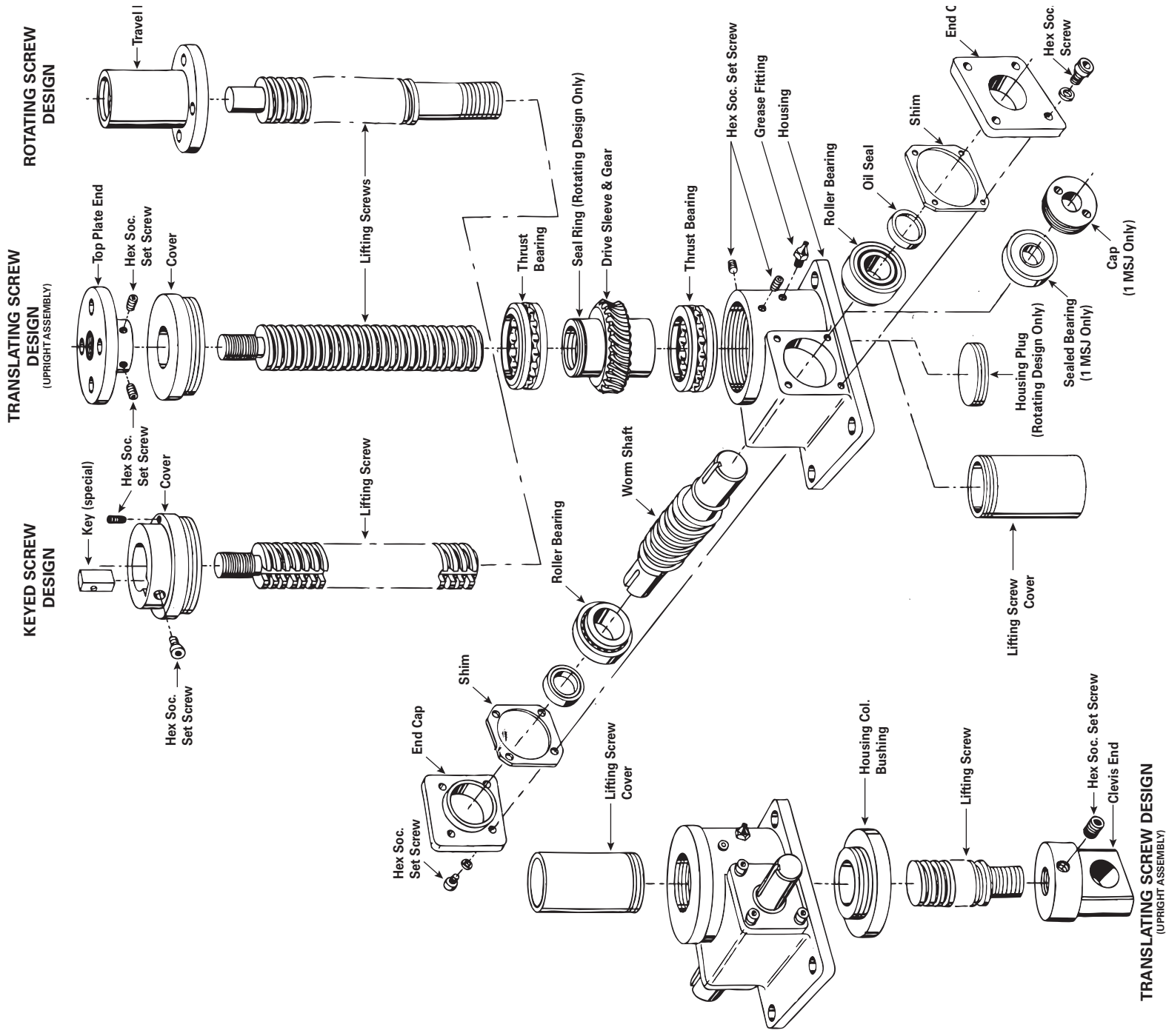

TRANSLATING SCREW DESIGN
(UPRIGHT ASSEMBLY)

3. Unscrew lifting screw from drive sleeve.
4. Remove socket head set screws in housing.
5. Unscrew housing cover.
6. Remove end caps on worm shaft assembly.

CAUTION - Handle shims carefully to avoid damage.

While tapping one end of the worm shaft with a wooden mallet, turn the worm shaft. This will loosen the bearing cup to facilitate removal. (2 MSJ - 100 MSJ only)

7. Remove the worm shaft bearing cups. (2 MSJ - 100 MSJ only)
8. Drive sleeve and gear assembly should now lift easily from housing.
9. Worm shaft assembly can be removed if necessary.

NOTES:

1. Bearing cones are press-fitted to worm shaft. If removal is required use bearing puller.
2. Removal of the bearings from the drive sleeves of Jacks equipped with Taper Roller bearings, may result in their being damaged.

Rotating Units Disassembly

1. Remove set screws from housing.
2. Unscrew housing cover.
3. Remove end caps on worm shaft assembly.

CAUTION - Handle shims carefully to avoid damage.

4. While tapping one end of the worm shaft with a wooden mallet, turn the

worm shaft. This will loosen the bearing cup to facilitate removal.

5. Remove the worm shaft bearing cups.
6. Drive sleeve and gear assembly can now be lifted easily from the housing.
7. Thrust bearing assembly can be removed if required. (see note 2)
8. Worm shaft assembly can be removed if necessary.

NOTES:

1. Bearing cones are press-fitted to worm shaft. If removal is required use bearing puller.
2. Removal of the bearings from the drive sleeves of Jacks equipped with Tapered Roller bearings, may result in their being damaged.

Keyed Units Disassembly

1. Remove key retaining bolt.
2. By turning worm shaft, drive lifting screw and key from housing and remove key.
3. Remove set screws from housing and cover.
4. Unscrew housing cover.
5. Remove end caps on worm shaft assembly.

CAUTION - Handle shims carefully to avoid damage.

6. While tapping one end of the worm shaft with a wooden mallet, turn the worm shaft. This will loosen the bearing cup to facilitate removal.
7. Remove the worm shaft bearing cups.

8. Drive sleeve and gear assembly should now lift easily from the housing.
9. Thrust bearing assembly can be removed if required. (see note 2)
10. Worm shaft assembly can be removed if necessary.

NOTES:

1. Bearing cones are press-fitted to worm shaft. If removal is required use bearing puller.
2. Removal of the bearings from the drive sleeves of Jacks equipped with

Tapered Roller bearings, may result in their being damaged.

REASSEMBLY

Your jack can be easily reassembled by reversing the procedure as previously outlined. In reversing disassembly procedures, be sure to pack worm, worm gear, and all bearings with grease. Also coat all seal areas with grease. After unit is reassembled, fill with grease, see page 3.

Reassembly may required that one worm shaft ball bearing be pressed onto worm shaft after drive sleeve and worm are assembled in the housing.

TROUBLE SHOOTING TIPS

Your ActionJac™ Machine Screw Jack will perform satisfactorily if suggestions described in this booklet are carefully followed. It is estimated that approximately 98 percent of Machine Screw Jack failures can be attributed to improper lubrication, misapplication, and misalignment.

TROUBLESHOOTING CHART

| TROUBLE | WHAT TO INSPECT | ACTION |
|--------------------|---|---|
| Worm Shaft Failure | 1. Type of Coupling | Rigid Couplings can cause shaft failure. Replace with coupling will provide adequate flexibility and lateral float. |
| | 2. Coupling Alignment | Realign as required. |
| | 3. Presence of Excessive Overhung Load | Check jack for allowable loads. |
| | 4. Unit Overload | See Housing Failure No.1. |
| | 5. Shock Loading | Apply coupling capable of absorbing shock and, if necessary, replace with unit of sufficient capacity. Shock loads can significantly increase apparent dead weight loads. |
| 6. "Ganging" Units | If several units are "in-line", the worm shaft of the first unit can assume 300% of the rated input torque. If this value is exceeded, you must replace with a larger unit. | |

TROUBLESHOOTING CHART (continued)

| TROUBLE | WHAT TO INSPECT | ACTION |
|-----------------------------------|-------------------------------|---|
| Housing Failure | 1. Unit Overload | Reduce load or replace with unit of sufficient capacity. |
| | 2. Improper Support | Unit should be supported over entire base area, not just at bolt hole locations. |
| | 3. Uneven Bolting Torque | Take up evenly on mounting bolts. |
| Bearing Failure | 1. Unit Overload | See housing failure No.1 |
| | 2. Excessive Overhung Load | See worm shaft failure No. 3 |
| | 3. Coupling Alignment | See worm shaft failure No. 2 |
| | 4. Coupling Lateral Alignment | Adjust spacing between connecting shafts to relieve end pressure. |
| | 5. Bearing Adjustment | Bearings must not be pinched. Adjustable tapered bearings must be set at proper lateral clearance. All shafts should turn freely when disconnected from the load. |
| | 6. Bearing Lubrication | Add lubricant if necessary |
| | 7. Shock Loading | See worm shaft failure No. 5 |
| Drive Sleeve & Worm Gear Wear | 1. Unit overload | See housing failure No.1 |
| | 2. Bearing Adjustment | See bearing Failure No. 6. |
| | 3. Lubrication | Proper levels and grade must be maintained. See lubrication page. |
| Drive Sleeve & Worm Gear Nut Wear | 1. Unit Overload | See housing failure No. 1 |
| | 2. Alignment | Lifting shafts must be perfectly plumb. |
| | 3. Lubrication | See Gear Wear No.3 |
| | 4. Side Load | Eliminate side load |
| Lifting Screw Failure | 1. Unit Overload | See housing failure No. 1. |
| | 2. Alignment | See lifting shaft failure No. 2. |
| | 3. Side Load | Check with Nook Industries Engineering Department for allowable size load. |

ANTI-BACKLASH ADJUSTMENT

The anti-backlash feature is set at the factory and normally does not require further adjustment. However, as wear develops with extended use, it may become necessary to adjust lash.

ADJUSTMENT PROCEDURE

- Loosen Locknut (Item a)
- Loosen Set Screw(s) (Item c)
- To reduce backlash, rotate Adjusting Cap (Item a) clockwise until resistance is felt. (Do not over tighten)
- Place a reference mark between thread on Adjusting Cap and Housing.
- Rotate Adjusting Cap (Item A) counter clockwise an amount equal to the A dimension on the o.d. of the threads. (See chart)
- Tighten Set Screws.
- Holding Adjusting Cap (Item a) stationary, tighten Locknut (Item b).
- Operate jack through entire stroke, checking for tight spots. Note: If jack has been used only over a portion of its stroke, backlash should be adjusted in the least worn portion of the screw.

CAUTION - Care should be taken not to overtighten the anti-backlash system in order to prevent binding or lockup between the drive nut and lifting screw. Overtightening can cause a destructive heat buildup or failure.

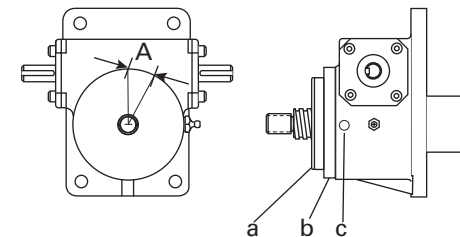

| Item | Description | Jack Model | A |
|------|---------------|----------------|-----------------|
| a | Adjusting Cap | 1, 2, 2.5-MSJ | $\frac{7}{32}$ |
| b | Locknut | 5, 10-MSJ | $\frac{5}{16}$ |
| c | Set Screw | 15, 20, 30-MSJ | $\frac{3}{8}$ |
| | | 35-MSJ | $\frac{1}{2}$ |
| | | 50-MSJ | $\frac{11}{16}$ |
| | | 75-MSJ | $\frac{13}{16}$ |
| | | 100-MSJ | 1 |

STATEMENT OF ASSURANCE

Thank you for purchasing another quality product from Nook Industries, Inc. Every effort has been taken to assure this product was manufactured to the highest industry standards of quality, precision, and performance.

GUARANTEE

Unless otherwise stated herein, Seller will repair or replace, without charge, f.o.b. point of shipment, any parts proven to Seller's satisfaction and upon Seller's examination to have been defective in material or workmanship when furnished to the original purchaser, provided claim is made within five (5) years after date of shipment of ¼ ton to 20 ton jacks or within one (1) year after date of shipment for jacks 30 tons and larger. Deterioration or wear occasioned by abuse, severe eccentric loading, overloading, chemical or abrasive action, or excessive heat shall not constitute defects. Equipment and accessories not of the Seller's manufacture are warranted only to the extent that they are warranted by the manufacturers, and this warranty is applicable only if the defect was the result of normal use, application, and service, and is void if the product or any part hereof was tampered with, repaired, or altered by any person other than the factory or authorized repair station. THERE ARE NO OTHER WARRANTIES, EXPRESS OR IMPLIED, INCLUDING THAT OF MERCHANTABILITY AND OF FITNESS FOR A PARTICULAR USE.

Under no circumstances shall Seller be liable for any loss of profit or for special, consequential, or exemplary damages over and apart from the repair or replacement of Seller's part.

This warranty and any controversy or claim arising out of this warranty or its interpretation, or any breach thereof, which cannot be amicably resolved between Seller and the original purchaser with sixty (60) days of written notice by the aggrieved party to the other, shall be finally settled by binding arbitration submitted to the three (3) arbitrators selected from the panels of the arbitrators of the American Arbitrator's Association in accordance with the rules and regulations of the American Arbitrator's Association sitting in Cleveland, Ohio, with each party to pay its own cost.

Authorization for return must be received from Nook Industries before returning any equipment for inspection or warranty repair.

WARNING

The equipment shown in this bulletin is intended for industrial use only and should not be used to lift, support, or otherwise transport human cargo, unless you have a written statement from Nook Industries, Inc. that the Jack unit as used in your application is suitable for human cargo.

