

ACTIONJAC™ CYLINDERS

ActionJac™ Electric Cylinders are ruggedly designed and produced in standard models with thrust capacities from 500 lbs. to 40,000 lbs. Electric Cylinders are intended for use in industrial environments and feature ground and hard chrome plated actuator tubes with industrial enamel paint on exterior surfaces. Epoxy paint available on request. Electric Cylinders can be supplied for outdoor applications.

These cylinders may be used individually or in multiple arrangements. Each ActionJac™ Electric Cylinder is built to specification.

**DD WORM GEAR
ELECTRIC CYLINDERS**

DD or “Direct Drive” worm gear driven Electric Cylinders incorporate an alloy steel worm which drives a high strength bronze worm gear (drive sleeve). The worm shaft is supported on anti-friction tapered roller bearings with external

seals provided to prevent loss of lubrication (sealed radial ball bearings on the Series 5 and Series 10 units). The drive sleeve is supported on anti-friction tapered roller or ball thrust bearings. The jack housing is made of ductile iron and proportioned to support the rated capacity of the unit.

In operation, the drive sleeve rotates the lift shaft causing the actuator tube to extend and retract from the housing tube. Actuator tube must be secured to prevent rotation.

Motors can be mounted to DD Electric Cylinders by using available standard motor mounts. For use in multiple cylinder arrangements, DD Electric Cylinders can be supplied without motor mounts.

The DD Electric Cylinders are available in Acme Screw or Ball Screw versions and have a variety of worm gear ratios resulting in a wide range of speeds and thrust capacities. **(SEE FIG. 1)**

**RAD WORM GEAR
ELECTRIC CYLINDERS**

RAD worm gear driven Electric Cylinders incorporate the features of the DD with a second stage of gear reduction. This secondary worm gear reduction of the RAD Electric Cylinders provides higher thrust at lower speeds. The reducer and motor can be mounted in eight possible positions for maximum flexibility.

RAD Electric Cylinders are available in Acme Screw or Ball Screw versions. **(SEE FIG. 1)**

ILA ELECTRIC CYLINDER

The ILA ActionJac™ In-Line Electric Cylinders are designed to have a motor or gear reducer directly coupled to the lift shaft. This provides for fast, precise operation and/or higher duty cycles.

ILA Electric Cylinders feature standard trunnion pin mounting and are easily adapted for use with servo motors and planetary gear reducers. **(SEE FIG. 1)**

FIG.1

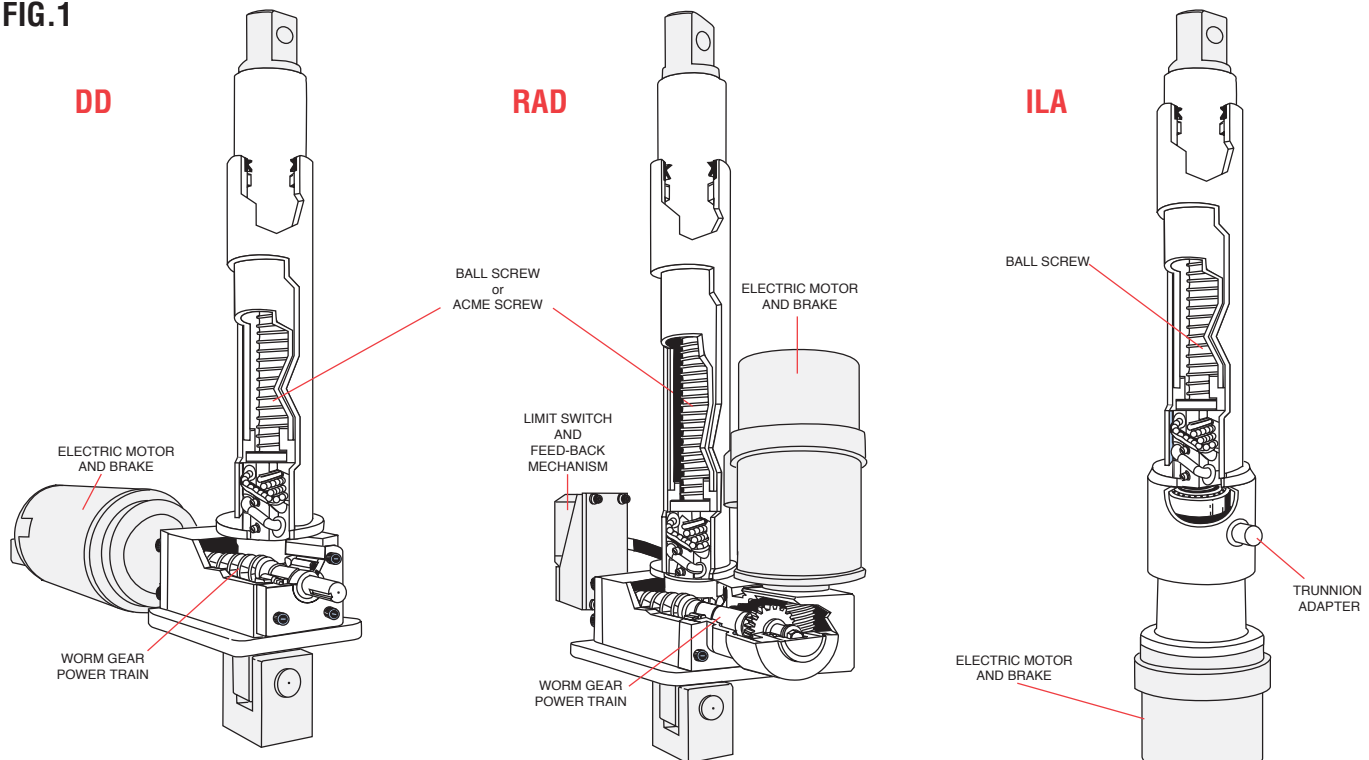

In-line Electric Cylinders are Ball Screw actuated. Configurations are available with keyed and un-keyed actuator tubes.

ACCESSORIES

Accessories such as motors, motor mounts, encoders, hand wheels, counters, couplings, miter gear boxes, boots, limit switches, clevises, clevis pins and clevis brackets are available. (SEE FIG. 2)

NOTE: Units are not to be used for personnel support or movement.

GLOSSARY & TERMS

BACKLASH

Backlash (lash) is the relative axial movement between a screw and nut without rotation of the screw or nut. Backlash in cylinders occurs wherever reversible load conditions exist. Backlash is less than .015" for all but the largest cylinder models.

Ball Screw Cylinders can be factory adjusted to reduce backlash at the lift shaft by selecting bearing ball size in the ball nut. This selective fit technique can be used to achieve a minimal lash between the ball nut and ball screw of .003" to .005". Precision ball screws with preloaded nuts can be supplied when less than .003" backlash is required.

REACTION TORQUE

When an electric cylinder is used to move a load, the actuator tube must be secured to prevent rotation. The reaction torque required to prevent rotation is a function of the screw lead and the load applied on the cylinder. See product specification sheets for rod reaction torque.

Prior to installation, the actuator tube can rotate freely in or out of the cylinder without movement of the input worm. This ability to rotate

aids installation but prevents the optional rotary limit switch from being factory preset for end of travel positions.

Rod-Type Limit Switches prevent tube from freely rotating but are not intended to absorb rod reaction torque.

TRAVEL LENGTH

Electric Cylinders are not pre-assembled or stocked with standard length screws. Each cylinder is made to order based on travel length.

Cylinders can be built with non-standard lead screws to change the cylinder operating speed or with ground or preloaded screws if required by the application. Contact Nook Industries for availability of special units.

FIG.2

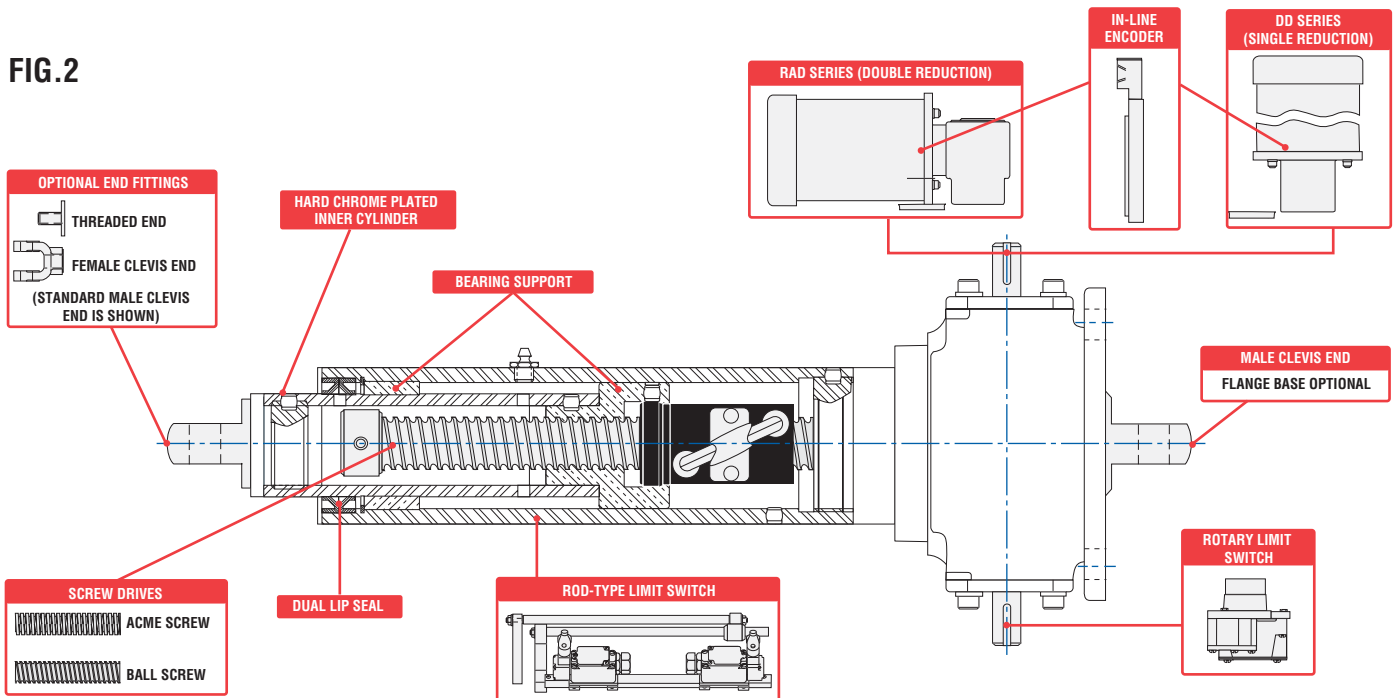



LEAD ACCURACY

Lead accuracy is the difference between the actual distance traveled versus the theoretical distance traveled based on lead. For example: Consider a lift shaft with a .5" lead and +/- .004"/foot lead accuracy. If the shaft is rotated 24 times, the distance the nut moves is 11.996 to 12.004 inches.

The rolled thread screws, as employed in ActionJac™ products, are held within +/- .004" per foot lead error.

INPUT TORQUE

The input torque is the rotary force required at the input of the cylinder to generate an output force at the actuator tube. The torque necessary to raise one pound is shown in charts on pages 384-385. This number multiplied by the load is the required input torque.

Due to static friction, starting or "breakaway" torque can be as much as two to three times running torque. If the load is moved horizontally, the force required to move the load will be lessened in proportion to the coefficient of friction of the surface along which the load is moved. In addition, the force needed to start, stop and hold the load (inertia loading) is provided by the cylinder. Cylinder sizing should consider all these forces.

If an application calls for several cylinders to be driven together in series, input torque values should be limited to three times the rated value of the first cylinder. For multiple high lead (HL, SL) ball screw cylinders contact Nook Industries for allowable input torque values. Multiple cylinders driven in a series may require operation at reduced load.

INPUT SPEED

DD and RAD ActionJac™ Electric Cylinder models are rated at 1725

rpm input. If provided without a motor, cylinders may be operated up to 3000 rpm provided horsepower and temperature ratings are not exceeded. Contact Nook Industries engineers if higher speeds are required.

When using variable speed motors, use the Input Turns Per Inch Of Travel information from the Electric Cylinder Design Data table to determine actual travel speed. Input speed (rpm) divided by input turns per inch of travel produces the travel speed in inches per minute.

NOTE: That maximum horsepower values should not be exceeded.

DUTY CYCLE

Duty cycle is the ratio of run time to total cycle time. Some of the electrical energy input to an electric cylinder is converted into heat. The duty cycle is limited by the ability of the electric cylinder to dissipate this heat. An increase in temperature can affect the properties of some components resulting in accelerated wear, damage and possible unexpected failure.

Ratings for DD and RAD Electric Cylinders are based on intermittent operation. The approximate allowable duty cycles for DD and RAD worm gear cylinders are:

Ball Screw versions = 35%

Acme Screw versions = 25%

Housing temperature should be monitored and kept below 200°F maximum. Continuous or heavy-duty operation is possible by de-rating the cylinder capacity, external cooling of the unit or through the use of a recirculating lubrication system.

ILA and ILAK cylinders are direct drives with no internal gears. Duty cycle for these cylinders is a function of the motor or add-on gear box.

SELF-LOCKING AND BRAKES

Self-locking occurs when system efficiencies are low enough that the force on the actuator lifting tube cannot cause the drive system to reverse direction. Actionjac Electric Cylinders that utilize acme screws and have ratios of 20:1 or greater are self-locking and, in the absence of vibration, will hold loads without backdriving. All other models require a motor brake to prevent backdriving.

Holding torque is the amount of input torque required to restrain the load once stopped. The standard brake torque shown in the product specification sheets for DD and RAD Cylinders will stop low inertia loads within the stopping distances shown. Larger brakes may be required to stop high inertial loads or stop travel in shorter distances. Contact Nook Industries, for recommendations.

TEMPERATURE

All Actionjac™ Electric Cylinders are suitable for operation within the specified limits, provided that the housing temperature is not lower than -20°F or higher than +200°F. Factory supplied grease in standard units will operate in this range. For higher or lower operating temperature ranges contact Nook Industries, for recommendations.

END-OF-TRAVEL STOPS

Travel stops are not standard. A limit switch and a brake should be used to stop the motor. Mechanical stops can cause damage to the cylinders because most electric motors will deliver stall torques much higher than their rated torques and motor inertia can cause severe shock loads. For hand operation, mechanical stops can be provided.

DESIGN CONSIDERATIONS

BALL SCREW VS. ACME SCREW CYLINDER

The decision to use a Ball Screw or an Acme Screw Cylinder is based on the application. For many applications, a ball screw model is the best choice. Ball screw cylinders are more efficient and therefore require less power than an acme screw cylinder in the same application.

For low duty cycle applications, for hand-operated applications, or if backdriving is not acceptable consider an acme screw cylinder.

Ball Screw Cylinders are preferred for:

- Long, predictable life
- High duty cycles
- Oscillating motion

Acme cylinder is preferred for:

- Resistance to backdriving
- Vibration environments
- High static loads

LOAD CAPACITY

All anticipated loads should be within the rated capacity of the cylinder. Loads on the cylinder in most applications include: static loads, dynamic or moving loads, cutting forces or other reaction forces and acceleration/ deceleration loads.

For shock loads, the peak load must not exceed the rated capacity of the cylinder, and an appropriate design factor should be applied commensurate with the severity of the shock.

For accidental overloads not anticipated in the design of the system, cylinders can sustain without damage the following

overload conditions: 10% for dynamic loads, 30% for static loads.

For multiple cylinder systems, load distribution should be considered. System stiffness, center of gravity, drive shaft windup and lead variation in the lift shafts may result in unequal load distribution.

HORSEPOWER RATINGS

Standard DD and RAD Electric Cylinder Models are supplied with electric brake-motors sized for the load and speed rating of the cylinder.

The allowable duty cycles for DD and RAD worm gear cylinders being used at full rated load are:

Ball Screw Cylinders = 35%

Acme Screw Cylinders = 25%

If an Electric Cylinder is applied at less than rated capacity, higher duty cycles may be possible. The best way to determine allowable duty cycle is to measure the cylinder gear housing temperature. The temperature of the housing near the worm must not exceed 200°F.

For Electric Cylinders supplied without brakemotors, use the information in the “Electric Cylinder Design Data” chart for motor sizing.

The horsepower is calculated by using the following formula:

$$\text{Horsepower per cylinder} = \frac{\text{Torque to raise one pound} \times \text{Number of pounds to be raised} \times \text{Input rpm}}{63,025}$$

The “Torque to raise one pound” value is particular to each cylinder and can be obtained from the “Electric Cylinder Design Data” chart on pages 384-385.

Maximum horsepower ratings are based on intermittent operation.

To determine whether performance is within horsepower and duty cycle limits, measure the cylinder temperature. The temperature of the housing near the worm (or at the thrust bearing mounting block for ILA cylinders) must not exceed 200°F.

Do not exceed the maximum allowable input horsepower for a cylinder.

COLUMN STRENGTH

Electric Cylinder capacity may be limited by its column strength. Column strength is the ability of the cylinder to hold compressive loads without buckling. With longer screw lengths, column strength can be substantially lower than nominal cylinder capacity. When the lift screw is in tension only, stroke is limited by available screw and/or tube material or by screw critical speed. If there is any possibility for the cylinder to go into compression, the application should be checked for sufficient column strength.

The charts on each cylinder specification page are used to determine the cylinder size in applications where the lift screw is loaded in compression.

The charts assume proper cylinder alignment with no bending loads present. Effects from side loading are not included in this chart. Also, cylinders operating horizontally with long lift screws can have significant bending from the weight of the screw and tubes. Consult Nook Industries, if side loads are anticipated.



CYLINDER SIZING DATA

Cylinders are limited by two constraints: load capacity and horsepower. The load capacity of the cylinder is limited by the physical constraints of its components (drive sleeve, lift shaft, bearings, etc.). The horsepower limit of the cylinder is a result of the ability to dissipate the heat generated from the inefficiencies of its components.

In order to test for these constraints, application information must be collected. The data required to size a cylinder includes:

1) Total Load – The total load includes static loads, dynamic loads and inertia loads from acceleration and deceleration. Also consider reaction forces received from the load such as drilling or cutting forces when using a cylinder to move a machine tool.

2) Number of Cylinders – The number of cylinders used depends on physical size and design of the equipment. Stiffness of the equipment structure and guide system will determine the appropriate number of cylinders required. Fewer cylinders are easier to drive, align and synchronize. For multiple-cylinder arrangements, do not assume equal loading. Calculations should be based upon “worst case” unequal loading.

3) Travel Rate – Establishing a travel rate allows for a quick cylinder selection and will be used to evaluate critical speed and horsepower limits. The desired rate should include time for acceleration/deceleration.

4) Travel – Travel is the total distance the cylinder extends. This is the number that is used to calculate maximum compressive load. For cylinders with non-standard retracted lengths include

the additional length in the compressive load evaluation.

5) Duty Cycle – The duty cycle is the ratio of run time to the total cycle time.

6) Type of Guidance – Every linear motion system needs something to move the load and something to guide the load. The degree of guidance (stiffness, accuracy, etc.) is based on application requirements.

CYLINDER SELECTION

Once the cylinder sizing information is collected, a preliminary cylinder selection can be made and verified.

1) Select a standard cylinder – Use the DD and RAD Model Quick Reference Chart page 374 to find a unit which matches the desired force and speed. Choose between a ball screw or acme screw model based on duty cycle (model suffixes which begin with “A” are acme models).

2) Travel Length – When a unit is chosen, go to the product specification page for that model. Check that the desired travel length does not exceed column strength and maximum travel limits. A larger capacity cylinder may be required in order to stay within these limits.

3) Reference Number – Use the information on page 389 to specify a complete Electric Cylinder Reference Number.

If the cylinder is to be used with a motor other than those listed in the catalog, if multiple cylinders are used or if the cylinder is manually operated, go to the Electric Cylinder Design Data on pages 384-385.

1) Select a cylinder – Choose a model whose basic capacity matches or exceeds the expected

load. Make certain the dynamic and static loads do not exceed the cylinder capacity. In multiple cylinder applications, check the distribution of the load for potential uneven loading on the cylinders.

2) Speed – Use the “turns for one inch of travel” from the chart to determine the input speed required. If travel rate and motor speed are known, divide the motor speed (rpm) by the travel rate (inches per minute) to determine the “turns for one inch of travel.”

3) Motor Horsepower – Calculate the horsepower required from the load, speed and “torque to raise one pound value” from the chart. Use the horsepower calculation on page 369.

If using the cylinders in multiple cylinder systems, check the total horsepower. Remember that additional gearboxes and couplings used to distribute power to the cylinders are not 100% efficient.

If the horsepower required exceeds the maximum value for the cylinder selected, several solutions are possible.

- Use a larger cylinder model to increase the maximum allowable horsepower
- Use a Ball Screw Cylinder to reduce the power required to do the same work
- Operate at a lower input speed
- Use a RAD cylinder to bring the power requirement within acceptable limits

Upon selecting a motor and brake, verify that the brake has sufficient torque to both hold the load and stop the load.

CAUTION: Cylinders with high lead ball screws (HL and SL) may

require larger brakes to stop the load. An appropriately sized brake will insure against excessive “drift”.

4) Column Strength – If it is possible for the cylinder to be loaded in compression, check for column strength. Consider cases where a unit normally loaded in tension can be compressively loaded if it runs into an obstruction. Also check horizontal applications for compressive loading due to acceleration or deceleration.

5) Cycle Time – If using a worm gear style Electric Cylinder, make sure cycle time does not exceed the allowable duty cycles.

6) Life – For Ball Screw Cylinders, check life expectancy against the life charts.

7) Reference Number – Use the information on page 389 to specify a complete Electric Cylinder Reference Number.

INSTALLATION

The alignment of the cylinders directly affects their service life. Cylinders must be properly aligned in all planes so the actuator tube can move in and out without evidence of binding.

Since the majority of cylinder applications use the cylinders with clevis or trunnion mounts, simply align the clevises and install the cylinder.

Set limit switches before operating. Allow for drift when setting the position. The actuator tube can move (rotate) until the unit is installed. Turn the actuator tube in or out to get the cylinder to a known position before installation to prevent over-travel.

MAINTENANCE

ActionJac™ Electric Cylinders require minimum maintenance. In addition to maintaining lubrication

levels in the gearbox and tubes, the following items should be checked:

- The actuator tube should be kept free of dirt. If possible, the actuator should be returned to the retracted position when not in use.
- For acme cylinders, lash between the lift shaft and travel nut greater than 1/4 the screw pitch indicates the need for replacement of the cylinder lift shaft components. Refer to the acme section for the specifications on the nut used.
- For machine screw or ball screw worm gear Electric Cylinders, check for excessive backlash between the worm and worm gear. Lash in excess of 30° for ratios 5:1 to 8:1 and 60° for ratios 20:1 and 24:1 indicates the need to replace the worm and worm gear.

LUBRICATION

Actionjac™ Electric Cylinders require lubrication to operate efficiently and with maximum life. Standard lubrication is NLGI #1 grease. If operating conditions exceed -20° F to 200° F, contact Nook Industries, for alternative lubricants.

The cylinder gear boxes are shipped pre-greased unless otherwise specified. Before operating any unit, check the lubricant level. All cylinder housings are furnished with a grease fitting. Most have a pipe plug opposite the grease fitting. When adding grease to the housing, remove the pipe plug and fill the unit until grease exits the pipe plug opening. Overfilling the cylinder may result in grease leakage from the seals.

In normal operation, cylinder lubricant levels should be checked once per month. Application conditions may dictate a more or

less frequent lubrication cycle. In extreme conditions, automatic lubrication may be desired.

Lubricants containing additives such as molydisulfide or graphite should not be used.

The lift shafts (ball and acme screws) inside the Electric Cylinder actuator tube receive lubrication through the fittings on the outside of the housing tube. Lubrication added to the housing tube can pass to the screw regardless of actuator tube position, but there is a guide at the bottom outside of the actuator tube which runs along the inside of the housing tube. The best way to lubricate this section of the cylinder is to add some lubricant when the cylinder is fully retracted and additional lubricant when the cylinder is extended beyond where the guide is past the lube port (see cylinder cutaway view on page 367).



Application #1 – HVAC DUCT VALVE

An HVAC 6' x 6' duct valve is located 30 feet above a manufacturing process facility floor. The baffle needs to be adjusted periodically to maintain proper airflow through the building. The loads, duty cycle and other operation details have been identified. The concern is with the amount of dust and particulate that will accumulate on the actuator due to the fact that it is located directly above foam manufacturing equipment.

SPECIFICATIONS:

- Maximum force to open and close the valve under maximum airflow is 2,000 lbs.
- Cylinder will be in compression
- Maximum speed is 32 inches per minute
- Actuation cycle: 2 times per day; 365 days per year
- Desired design life is twenty years
- Mechanism must be mounted overhead
- Limit Switches needed
- Maximum stroke is 18 inches

ANALYSIS:

There is a specific life requirement so a ball screw actuator is needed. As shown on the Series DD-25 product reference page 366, using the DD-2512-HD with a 1/2 hp brake motor will provide a travel rate of 36"/min and give 4.1 million inches of life at 2000lbs. Additionally, the charts show that this application is within the column load strength of the DD-2512-HD. The door swings through an arc so a double clevis style will be needed. Due to the environment concerns an enclosed Rotary Limit Switch should be used instead of a Rod type Limit Switch.

SELECTION:

DD-2512-HD / 05BT -1 / 2CA – 4E / CC / 18 / S

Application #2 – DISTRIBUTION CONVEYOR

A warehouse conveyor system distributes filler material across a 48 inch wide packaging line. One end of the conveyor is hinged to a loading station, the other end must move across the conveyor.

SPECIFICATIONS:

- The maximum load from the conveyor with material is 1,100 pounds
- A servo drive will be used to control the actuator
- The conveyor will move 480 times an hour, 16 hours a day, 350 days per year
- Life expectancy is 5 years
- Stroke length is 24 inches maximum
- Minimum Travel Rate is 24 inches in 3 seconds

ANALYSIS:

An In-Line cylinder will be used because of the frequent cycle requirement. With a travel rate of 480 inches per min ((24 inches / 3 seconds) * 60 seconds) and a life expectancy of 15 million inches, an ILA-10-HL is selected. The application would require a servomotor that can produce 96.8 inch-lbs of torque (0.088 inch-lbs * 1,100 lbs) at 960 rpm (480 inches per min / .500 Lead).

SELECTION:

ILA-10-HL / 24 / M

M- Modified motor adapter to mount servomotor.

LOAD

Total Maximum Thrust Load on Cylinder(s): _____ pounds force Number of Cylinders: _____

Maximum Thrust Load on any one Cylinder: _____ pounds force
(Note: load can rarely be assumed to be equal on all cylinders)

TRAVEL

Inches: _____ Orientation: vertical horizontal other (arc, diagonal, etc)

TRAVEL RATE

Optimal Speed: _____ inches/minute

Minimum Acceptable Speed: _____ inches/minute Maximum Acceptable Speed: _____ inches/minute

DUTY CYCLE

Distance per cycle _____ inches (One cycle = extend and retract)

Number of cycles per time period: _____ cycles per

Maximum Distance Traveled in any Year: _____ inches

Life Desired: _____ (Important: If load varies significantly, please explain below.)

OPERATION

Cylinders are Loaded in: Tension Compression Both

Driven Motor type: Servo AC Induction motor Other Type of motor (describe)

APPLICATION

Please briefly describe the application. State type of machine, function of jack(s), load guidance system and environment (shock or impact loading, vibration, temperature extremes, corrosive, dirty, or other extreme operating conditions). Attach any sketches and other relevant information. Also, if a tentative selection has been made, please give the reference number or model and description below.
