



The Right-Angle Reducer is a compact, high quality worm gear reducer enclosed in a ductile iron housing. The reducer mounts directly to the input side of the jack. Motors mount quill-style to a standard NEMA C-face.

The right angle reducer is a secondary worm gear reducer that reduces speed and increases torque to the input of the jack. If motor clearance is an issue, a right angle reducer may be added to most jacks to optimize motor orientation.

Right Angle Reducers may be ordered installed on the standard ActionJac™ Machine Screw and Ball Screw Jacks listed below and are available with or without brakemotors.

Consult the data charts for jack capacity when a Right-Angle Reducer is used. Ratings given on the chart may differ when a Right-Angle Reducer is installed on Keyed or Anti-Backlash Machine Screw Jack models. Special consideration must be given when installing onto a Double-Clevis Jack due to the additional weight of the reducer.

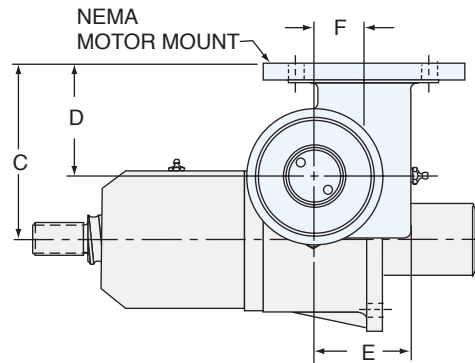
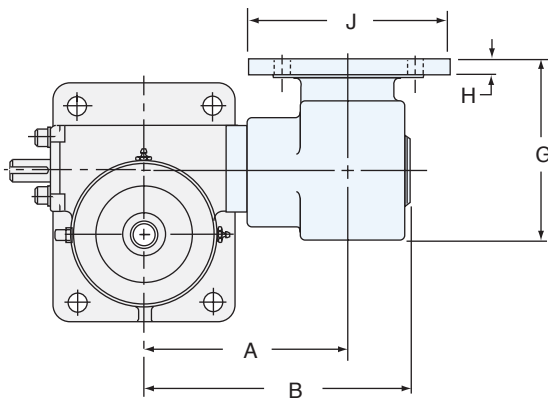

RIGHT-ANGLE REDUCER POSITIONS			
POSITION 1			POSITION 2
POSITION 3			POSITION 4
POSITION 5			POSITION 6
POSITION 7			POSITION 8

RIGHT-ANGLE REDUCERS FOR BALL SCREW JACKS																		
JACK MODEL-RATIO	REDUCER RATIO	TRAVEL RATE IN/MIN. @ 1725 RPM	BRAKE MOTOR HP	DYNAMIC CAPACITY* (LBS.)	ORDER CODE**			MOTOR SIZE	REDUCER DIMENSIONS									
					W/1-PH MOTOR	W/3-PH MOTOR	WITHOUT MOTOR		A	B	C	D	E	F	G	H	J	
2.5-BSJ-6:1	6:1	12.0	1/2	5,000	05BSR6	05BTR6	X05R6	56C	5.63	7.44	5.44	3.69	3.31	1.750	5.88	.50	6.69	
	12:1	5.99	1/3	5,000	03BSR12	03BTR12	X05R12											
2.5-BSJ-24:1	6:1	2.99	1/4	5,000	02BSR6	02BTR6	X05R6											
	12:1	1.48	1/4	5,000	02BSR12	02BTR12	X05R12											
2.5HL-BSJ-6:1	6:1	47.9	1	2,370	10BSR6	10BTR6	X05R6											
	12:1	24.0	1	4,870	10BSR12	10BTR12	X05R12											
5-BSJ-6:1	6:1	22.7	1	6,300	10BSR6	10BTR6	X05R6		56C	6.50	8.50	5.88	3.69	3.31	1.750	5.88	.50	6.69
	12:1	11.3	1	10,000	10BSR12	10BTR12	X05R12											
5-BSJ-24:1	6:1	5.67	1	10,000	10BSR6	10BTR6	X05R6											
	12:1	2.83	1/2	10,000	05BSR12	05BTR12	X05R12											
5HL-BSJ-6:1	6:1	47.9	1	3,000	10BSR6	10BTR6	X05R6											
5HL-BSJ-24:1	6:1	12.0	1	7,400	10BSR6	10BTR6	X05R6											
10-BSJ-8:1	6:1	17.0	1	7,700	10BSR6	10BTR6	X05R6	56C	7.25	9.25	6.29	3.69	3.31	1.750	5.88	.50	6.69	
	12:1	8.50	1	13,000	10BSR12	10BTR12	X05R12											
10-BSJ-24:1	6:1	5.67	1	15,000	10BSR6	10BTR6	X05R6											
	12:1	2.83	1	20,000	10BSR12	10BTR12	X05R12											
10HL-BSJ-8:1	6:1	35.9	1	3,600	10BSR6	10BTR6	X05R6											
20-BSJ-8:1	8:1	13.5	3	40,000	N/A	30BTR8	X18R8											180TC
20-BSJ-24:1	8:1	4.49	2	40,000	N/A	20BTR8	X18R8											
20HL-BSJ8:1	8:1	26.9	5	40,000	N/A	50BTR8	X18R8											
20HLBSJ-24:1	8:1	8.98	3	40,000	N/A	30BTR8	X18R8											

RIGHT-ANGLE REDUCERS FOR MACHINE SCREW JACKS																											
JACK MODEL-RATIO	REDUCER RATIO	TRAVEL RATE IN/MIN. @ 1725 RPM	BRAKE MOTOR HP	DYNAMIC CAPACITY* (LBS.)	ORDER CODE			MOTOR SIZE	REDUCER DIMENSIONS																		
					W/1-PH MOTOR	W/3-PH MOTOR	WITHOUT MOTOR		A	B	C	D	E	F	G	H	J										
2.5-MSJ-6:1	6:1	12.0	1	4,610	10BSR6	10BTR6	X05R6	56C	5.63	7.44	5.44	3.69	3.31	1.750	5.88	.50	6.69										
	12:1	5.99	3/4	5,000	07BSR12	07BTR12	X05R12																				
2.5-MSJ-24:1	6:1	2.99	1/2	5,000	05BSR6	05BTR6	X05R6																				
	12:1	1.48	1/3	5,000	03BSR12	03BTR12	X05R12																				
5-MSJ-6:1	6:1	18.0	1	3,000	10BSR6	10BTR6	X05R6											56C	6.50	8.50	5.88	3.69	3.31	1.750	5.88	.50	6.69
	12:1	8.98	1	5,000	10BSR12	10BTR12	X05R12																				
5-MSJ-24:1	6:1	4.49	1	6,000	10BSR6	10BTR6	X05R6																				
	12:1	2.25	1	10,000	10BSR12	10BTR12	X05R12																				
10-MSJ-8:1	6:1	18.0	1	3,000	10BSR6	10BTR6	X05R6	56C	7.25	9.25	6.29	3.69	3.31	1.750	5.88	.50	6.69										
	12:1	8.98	1	5,000	10BSR12	10BTR12	X05R12																				
10-MSJ-24:1	6:1	5.99	1	6,000	10BSR6	10BTR6	X05R6																				
	12:1	2.99	1	10,000	10BSR12	10BTR12	X05R12																				
20-MSJ-8:1	8:1	13.5	7 1/2	40,000	N/A	75BTR8	X21R8											210TC	9.00	11.75	9.00	6.12	5.38	2.875	9.00	.88	9.12
	8:1	13.5	5	22,500	N/A	50BTR8	X18R8											180TC									
20MSJ-24:1	8:1	4.49	3	35,500	N/A	30BTR8	X18R8																				

*Full nominal static capacity of jack is retained

**Motor specified is internally wired brake motor, for additional motor options see page 276

HOW TO ORDER A RIGHT-ANGLE REDUCER:

Right-Angle Reducer ratio, mounting position and brakemotor size and type must be specified. The data chart above gives order codes for Right-Angle Reducers with and without brakemotors. Insert the order code and mounting position as shown on page 296, 317, 336, 345 and 358.

EXAMPLE: 2.5-BSJ-U 6:1 / **05BTR6 - 2** / 2CA-2 / FT / 24.5 / S



WORM GEAR SCREW JACK ACCESSORIES TECHNICAL DATA