

Actionjac™

BALL SCREW JACS

Installation, Maintenance and Lubrication Instructions

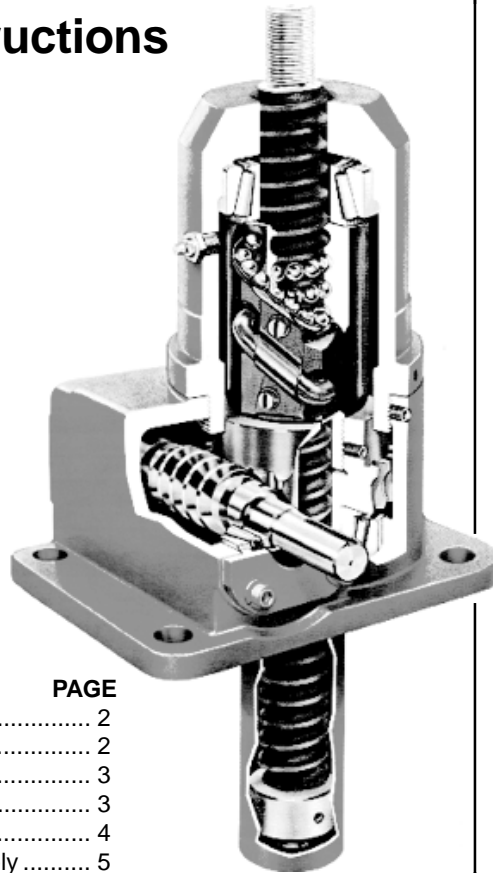

TABLE OF CONTENTS

	PAGE
General Instructions	2
Ordering Spare/Repair Parts	2
General Specifications	3
Lubrication	3
Installation Instructions	4
Tips for Disassembly & Reassembly	5
Disassembly Instructions	5-8
Exploded View of Jac Units	6-7
Reassembly	8-9
Troubleshooting	9-10



NOOK ...THE LINEAR MOTION PEOPLE

NOOK INDUSTRIES, INC.

CAUTION — The ActionJac™ Ball Screw Jac may be self-lowering and therefore the customer must provide some means of holding the load.

The customer is responsible for providing stops at either end of travel. Hard external safety stops are recommended, since failure of brake or system components could cause self-lowering.

GENERAL INSTRUCTIONS

Your ActionJac™ Ball Screw Jac is a high quality, sturdy unit designed to give many hours of trouble-free service. However, certain precautions and procedures must be observed in handling, installing and servicing the unit in order to obtain optimum performance.

1. Any apparent or suspected damage sustained by equipment manufactured or furnished by Nook Industries during transport from the factory to the user should be immediately reported to both Nook Industries and to the carrier.
2. Upon delivery all equipment furnished should be carefully inventoried against shipping papers to determine whether any shortages exist in delivered material. Any such shortages must immediately be reported to Nook Industries and the carrier if a timely claim is to be made.
3. The installation of most power transmission equipment does not normally require the services of a factory engineer. These services are not included in the selling price of the equipment unless specifically agreed upon in writing between the seller and purchaser. In applications requiring a more complex arrangement of components, consideration should be given to the use of a factory engineer

for construction supervision or check-out of the installation. These services are available from Nook Industries by contacting the Service Department.

4. The Seller's warranty applies insofar as the unit is operated within the rating and service conditions for which it was specifically sold. The purchaser must prevent the existence of any destructive external conditions which might typically include vibratory loads due to critical speeds, severe shock loading, mechanical or thermal overloads, or side loads if the seller was not fully advised of their existence at time of order.
5. Adequate installation, maintenance and safety instructions must be given by the user to personnel directly responsible for the installation and operation of the equipment.
6. In the event of malfunction within the warranty period, the manufacturer must be informed promptly or, in any event, within thirty days if it is intended that the warranty is to cover the incident.

ORDERING SPARE/REPAIR PARTS

This booklet contains general instructions, operating, maintenance and troubleshooting instructions for your ActionJac™ Worm Gear Jac. In the event spare or repair parts are required, call your local representative or contact Nook Industries at (216) 271-7900 or 1(800) 321-7800.

Please provide the following information when requesting spare/repair parts:

- Jac Size & Type Designation (i.e., 2 BSJ)
- Serial Number & Year of Manufacture (located on housing nameplate)
- Stroke Length
- Part Description (see pages 6-7).

CAUTION — UNITS ARE NOT MEANT FOR PERSONNEL SUPPORT. Refer all applications for potential personnel support to the factory for approval.

GENERAL SPECIFICATIONS

The worm gear driven Ball Screw Jac incorporates an alloy steel worm, which drives a high tensile bronze worm gear, accurately machined to the high standards of Nook Industries for maximum load carrying capacity and uniformity of motion transmission. All shafts are mounted on heavy duty, anti-friction bearings to increase operating efficiency of the drive mechanism. Thrust bearings are provided to support the rated thrust load of each unit. Housings are made of high strength material, well proportioned to handle the rated thrust and torque loads of each size unit.

Ball Screw Jacs with translating screws are fitted with a retainer for one direction of travel only. Its purpose is to avoid inadvertently running the lifting screw out of the jac and losing the balls from the ball nut. THIS RETAINER IS NOT DESIGNED TO FUNCTION AS A TRAVEL STOP. Care must be taken if this stop collar is removed as the ball screw can run out of the unit and the recirculating balls will be lost from the nut. Stops or collars are NOT provided for units with traveling nuts unless specifically requested.

CAUTION — In the absence of internal or external stops, it is possible to run the lifting screw out of the unit. Your Jac is NOT equipped with internal stops unless specifically requested in your order.

A lifting screw cover is threaded into the bottom of the unit on the upright model, or in the top of the unit on the inverted model, in order to keep the lifting screw

threads free of foreign material.

The lifting screw is made of 4150 heat treated steel. The threads of the lifting screw for all models should be well lubricated and kept free of grit, dirt or other abrasive contaminants.

Fabric type protective boots, or spiral steel protectors, can be provided as an accessory to protect the exposed portion of the lifting screw. In the absence of positive stops, overtravel may crush protective boots.

CAUTION — Standard units should not be operated at input speeds over 1,800 RPM without consulting the factory. Ball Screw Jacs are designed for a maximum of three hours intermittent operation per day. For values higher than three hours per day, for any continuous operation, or for repeated operation over any segment of total travel, consult factory.

LUBRICATION

Gear Box Enclosure

Ball Screw Jacs are shipped with grease in the unit. However, before operating any unit remove the housing plug and check the condition of the lubricant. Lubrication inspection is recommended at regular intervals. Usually one month intervals are satisfactory unless experience indicates that regreasing should occur at shorter or longer intervals.

Each jac unit is furnished with a grease fitting and a pipe plug on opposite sides of the housing. After removing the pipe plug, fill unit with grease until lubricant seeps from the pipe plug opening. Replace pipe plug. Severe operating conditions will shorten the lubrication inspection interval.

Lubricate upper bearing through grease fitting, Item No. 12, as shown on Typical Exploded View of a Jac on page 6.

The lubricant should not be corrosive to gears, ball or roller bearings and must be neutral in reaction. The lubricant must not contain any grit or dirt, abrasives or fillers. It should not precipitate sediment, nor separate at temperatures up to 300°F. The lubricant must also have resistance to oxidation and must be non-channeling. We recommend the following extreme pressure greases or equivalents. For operating conditions outside these limits consult factory.

COMPANY	TRADE NAME	TEMPERATURE RANGE
*Exxon	Nebulla EP#1	0 to 300°F
Mobil	Mobilux EP#1	-20 to 225°F
Arco	Litholine EP#1	-20 to 200°F
Gulf	Gulf Crown EP#1	0 to 250°F
Shell	Aeroshell #22	-85 to 400°F

*Calcium base. All others Lithium base.

Ball Screw Assembly

In the normal operating range (32°F to 160°F), oil or a good grade of light bearing grease may be used. Grease containing graphite or moly-disulfide should not be used. Use only enough lubricant to maintain a thin, continuous film.

All units are suitable for intermittent operation in ambient temperatures up to 200°F with proper grease. If protective boots are used, the material must be able to withstand the environment.

INSTALLATION INSTRUCTIONS

1. Be certain that the rating of the Jac exceeds the maximum load that may be imposed upon it.
2. The foundation for the unit must be rigid enough to maintain correct alignment with connected machinery and have ample strength to carry the maximum load.
3. The foundation should have a flat mounting surface to uniformly support

the Jac unit. The opening for the lifting screw cover (or lifting screw) that passes through base must be as small as possible to provide Jac support over the largest possible area.

4. It is extremely important that the Jac be installed so that the lifting screw is exactly plumb and that all connecting shafting is aligned with the worm shaft.
5. After precise alignment, each member must be securely bolted and, if possible, doweled in place. Doweling will assure exact repositioning if ever removed. It is essential that a jac unit be securely bolted down to its foundation using bolts of the proper diameter to fit mounting holes. Bolts should be S.A.E. Grade 5 or equivalent.

CAUTION — In the case of rotating units it is essential, for proper alignment and prevention of screw failure, that the load be attached to the traveling nut only when the load is in the position of travel closest to the Jac housing.

Torque values for bolting are as follows:

BOLT SIZE INCHES	APPROX. TORQUE VALUE FOOT POUNDS
1/4	6
3/8	20
1/2	50
5/8	100
3/4	165
7/8	265
1	400
1 1/4	830
1 1/2	1350
1 3/4	2500
2	3650

IMPORTANT — Take up evenly on mounting bolts to avoid damaging the housing.

6. After the Jacs, mitre boxes, couplings, etc. are installed and aligned, there should be no signs of binding or misalignment.
7. Shaft coupling guards are the responsibility of the customer and are not provided by Nook Industries unless specifically quoted to and ordered by the customer.
8. Caution must be taken when operating your Jac at either extreme of travel. If possible, hard external stops should be provided.
9. If operating at the upper limits of the unit rating, DO NOT STOP the travel of the unit by running the lifting screw attachments or the load against the housing without checking with Nook Industries, as serious damage to the internal mechanism may result. The customer is responsible for providing mechanical stops and switches for control of the prime mover. None are included unless specifically quoted by and ordered from Nook Industries.
10. Due to the inherently high translational efficiency, and non-locking worm gear sets, caution must be taken to prevent the load from lowering. Some means should be taken to secure the load while installing or removing the Jac.

CAUTION — If limit switches are furnished by Nook Industries, they are NOT factory set. Limit switches should be set by carefully moving to the set position by hand or jogging. Care must be taken to avoid running lifting screws out of units or crushing boots.

TIPS FOR DISASSEMBLY AND REASSEMBLY

CAUTION — Never perform any work on the Jac or associated transmission

equipment (mitre boxes, couplings, etc.), until absolutely certain that the prime mover cannot be remotely or automatically started. Also make certain that load cannot affect personnel or machinery when the Jac, brake, or other holding devices are removed. Be sure disassembly area is relatively clean to prevent contamination of parts. Store all machined parts on wooden blocks or skids to prevent damage to machined surfaces.

Before starting disassembly, carefully review a typical parts list or certified assembly drawing of the unit.

When removing end caps, be sure to tape shaft extension keyways and other sharp edges to avoid damaging oil seals.

NOTES:

1. Be sure to clean and dry all parts before rebuilding.
2. It is advisable to replace old seals when the unit is rebuilt.
3. Remove any protective coatings on replacement parts before installing.
4. On Jacs equipped with Tapered Roller bearings, removal of the bearings from the drive sleeve may result in their being damaged.

DISASSEMBLY INSTRUCTIONS *All BSJ Models*

Refer to typical parts assembly, pages 6-7.

These instructions are necessarily general, and as such, cannot provide for minor details of construction, which may vary from unit to unit.

For specific questions, consult factory giving order number and serial number from housing name plate.

ACTIONJAC™ BALL SCREW JAC

ALL MODELS 1/2 THROUGH 100 BSJ

EXPLODED VIEW OF A TYPICAL ASSEMBLY

Views are illustrative **only**. See page 2 for ordering spare/repair parts.

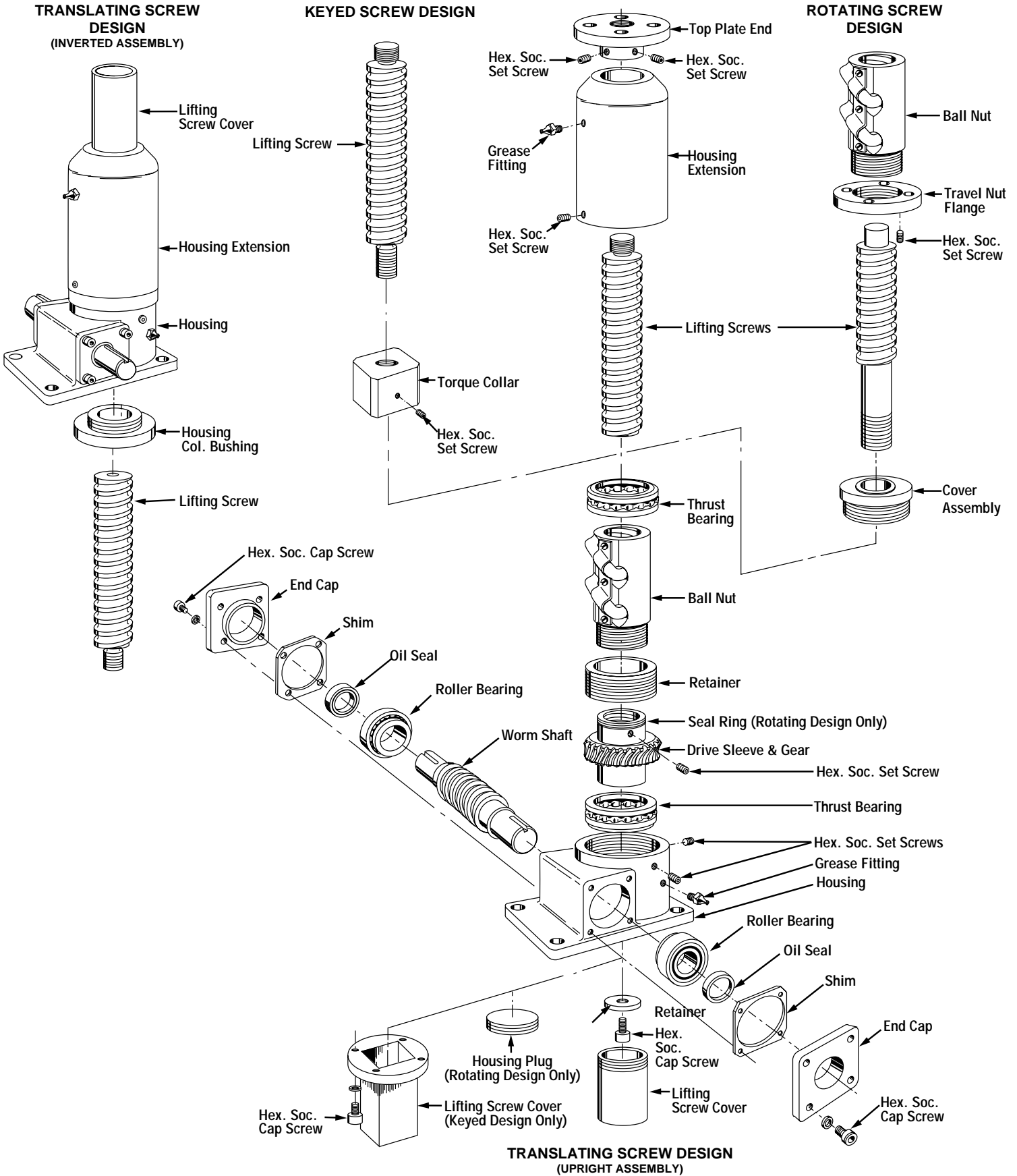

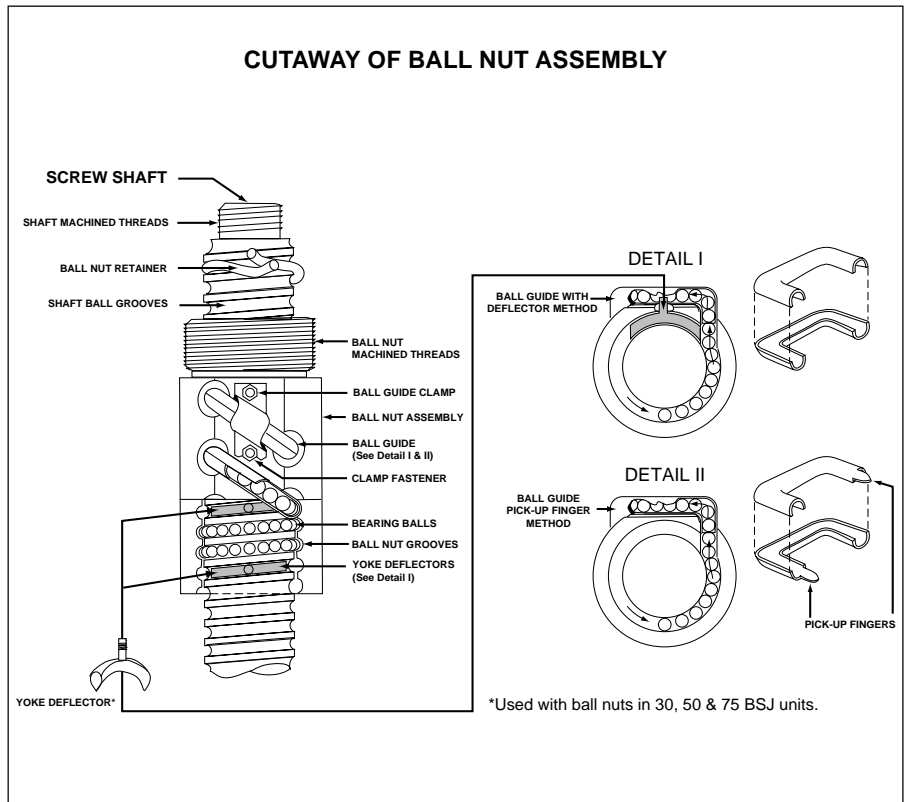

**Model 1/2- 100 BSJ,
Upright or Inverted**

1. Unscrew lifting screw cover assembly from unit.
 2. Remove protective boot and end attachment from lifting screw, if applicable.
- CAUTION**—Make certain lifting screw does not unscrew from ball nut. Use of heavy tape around lifting screw at each end of the nut will prevent this from happening.
3. Remove (2) socket head set screws locking housing extension. Unscrew extension from Jac.

4. On 20 and 30 BSJ units, remove (2) socket head set screws holding housing adapter (Item 18) to housing.
5. On 20-BSJ unscrew housing adapter.
6. On 30-BSJ screw housing adapter flush with the housing so that set screws locking ball nut to drive sleeve may be removed. Unscrew ball nut from drive sleeve and remove ball nut and screw. Unscrew housing adapter from housing.
7. Remove end caps (Item 3) on worm shaft assembly.

CAUTION—Handle shims carefully to avoid damage.

8. While tapping one end of the worm shaft with a wooden mallet, turn the worm shaft. This will loosen the bearing cup to facilitate removal.
9. Remove the worm shaft bearing cups.
10. Drive sleeve and gear, along with the ball nut and lifting screw, can now be removed from the housing.
11. Further disassembly is possible by removing set screws from drive sleeve.
12. For ball nut disassembly consult factory.

Rotating Units Disassembly

1. Remove 2 set screws from housing cover.
2. Unscrew housing cover.
3. Remove end caps on worm shaft assembly.

CAUTION—Handle shims carefully to avoid damage.

4. While tapping one end of the worm shaft with a wooden mallet, turn the worm shaft. This will loosen the bearing cup to facilitate removal.
5. Remove the worm shaft bearing cups.
6. Drive sleeve and gear, along with the ball nut and lifting screw, can now be removed from the housing.
7. For ball nut disassembly consult factory.

Keyed Units Disassembly

1. Unbolt lifting screw cover assembly from unit.
2. Remove pin on torque collar
3. Unscrew torque collar from lifting screw.

4. Remove set screw from locking housing extension. Unscrew extension from Jac.
5. On 20 and 30 BSJ units remove socket head set screws holding housing adapter to housing.
6. On 20-BSJ unscrew housing adapter.
7. On 30-BSJ screw housing adapter in flush with the housing so that set screws locking ball nut to drive sleeve may be removed. Unscrew ball nut from drive sleeve and remove ball nut and screw. Unscrew housing adapter from housing.
8. Remove end caps on worm shaft assembly.

CAUTION—Handle shims carefully to avoid damage.

9. While tapping one end of worm shaft with a wooden mallet, turn the worm shaft. This will loosen the bearing cup to facilitate removal.
10. Remove the worm shaft bearing cups.
11. Drive sleeve and gear, along with the ball nut and lifting screw, can now be removed from the housing.
12. Further disassembly is possible by removing set screws from drive sleeve.
13. For ball nut disassembly consult factory.

REASSEMBLY

Your Jac can be easily reassembled by reversing the procedure as previously outlined. In reversing disassembly procedures, be sure to pack worm, worm gear, and all bearings with grease. Also coat all seal areas with grease. After unit is reassembled, fill with grease, see page 3.

TROUBLE SHOOTING TIPS

Your ActionJac™ Ball Screw Jac will perform satisfactorily if suggestions described in this booklet are carefully followed. It is estimated that approximately 98 percent of Ball Screw Jac failures can be attributed to improper lubrication, misapplication, and misalignment.

TROUBLE SHOOTING CHART

TROUBLE	WHAT TO INSPECT	ACTION
Housing Failure	1. Unit Overload	Reduce load or replace with unit of sufficient capacity.
	2. Improper Support	Unit should be supported over entire base area, not just at bolt hole locations.
	3. High Shock	Select different material.
	4. Uneven Bolting Torque	Take up evenly on mounting bolts.
Worm Shaft Failure	1. Type of Coupling	Rigid Couplings can cause shaft failure. Replace with coupling which will provide adequate flexibility and lateral float.
	2. Coupling Alignment	Realign as required.
	3. Presence of Excessive Overhung Load	Check Jac for allowable loads.
	4. Unit Overload	See Housing Failure No. 1.
	5. Shock Loading	Apply coupling capable of absorbing shock and, if necessary, replace with unit of sufficient capacity. Shock loads can significantly increase apparent dead weight loads.
	6. "Ganging" Units	If several units are "in-line", the worm shaft of the first unit can assume 300% of the rated input torque. If this value is exceeded, you must replace with a larger unit.

TROUBLE SHOOTING CHART (continued)

TROUBLE	WHAT TO INSPECT	ACTION
Bearing Failure	1. Unit Overload	See Housing Failure No.1.
	2. Excessive Overhung Load	See Worm Shaft Failure No. 3.
	3. Coupling Alignment	See Worm Shaft Failure No. 2.
	4. Coupling Lateral Alignment	Adjust spacing between connecting shafts to relieve end pressure.
	5. Bearing Adjustment	Bearings must not be pinched. Adjustable tapered bearings must be set at proper lateral clearance. All shafts should turn freely when disconnected from the load.
	6. Bearing Lubrication	Add lubricant if necessary.
	7. Shock Loading	See Worm Shaft Failure No. 5.
Drive Sleeve & Worm Gear Wear	1. Unit Overload	See Housing Failure No. 1.
	2. Bearing Adjustment	See Bearing Failure No. 6.
	3. Lubrication	Proper levels and grade must be maintained. See lubrication page.
Ball Nut Failure	1. Unit Overload	See Housing Failure No. 1.
	2. Alignment	Lifting shafts must be perfectly plumb.
	3. Lubrication	See Gear Wear No. 3.
	4. Improper Selection	Refer to load/life predictability chart in Product Catalog.
Lifting Screw Failure	1. Unit Overload	See Housing Failure No. 1.
	2. Alignment	See Ball Nut Failure No. 2.
	3. Side Load	Check with Nook Industries Engineering Department for allowable side load.
	4. Improper Selection	See Ball Nut Failure No. 4.

Actionjac™ BALL SCREW JACS

STATEMENT OF ASSURANCE

Thank you for purchasing another quality product from Nook Industries, Inc. Every effort has been taken to assure this product was manufactured to the highest industry standards of quality, precision and performance.

WARRANTY

Unless otherwise stated herein, Seller will repair or replace, without charge, f.o.b. point of shipment, any parts proven to Seller's satisfaction and upon Seller's examination to have been defective in material or workmanship when furnished, provided claim is made within one year after date of shipment. Deterioration or wear occasioned by abuse, severe eccentric loading, overloading, chemical or abrasive action or excessive heat shall not constitute defects. Equipment and accessories not of the Seller's manufacture are warranted only to the extent that they are warranted by the manufacturers, and this warranty is applicable only if the defect was the result of normal use, application and service, and is void if the product or any part hereof was tampered with, repaired or altered by any person other than the factory or authorized repair station. THERE ARE NO OTHER WARRANTIES, EXPRESS, STATUTORY, OR IMPLIED, INCLUDING THAT OF MERCHANTABILITY AND OF FITNESS.

Authorization for return must be received from Nook Industries before returning any equipment for inspection or warranty repair.

WARNING

The equipment shown in this bulletin is intended for industrial use only and should not be used to lift, support, or otherwise transport human cargo, unless you have a written statement from Nook Industries, Inc. that the Jac unit as used in your application is suitable for lifting human cargo.

NOOK

ENGINEERING HOTLINE 
1-800-321-7800

NOOK INDUSTRIES, INC. 4950 EAST 49TH STREET • CLEVELAND, OHIO 44125-1016 USA
(216) 271-7900 • FAX (216) 271-7020
WEBSITE: NOOKIND.COM • E-MAIL: NOOK@NOOKIND.COM