

CONVENIENCE AND MODULARITY

These PowerAc™ modular assemblies are pre-engineered and feature a 2-C acme screw, steel mounting flange with choice of nut material, one single and one double bearing EZZE-MOUNT™ support. One end of the mounted screw is provided with a drive shaft and keyway for coupling the assembly to a drive mechanism.

Use the reference number below to select the assembly that meets the design requirement. See page 214-218 for EZZE-MOUNT™ information and page 212-213 for End Machining information.

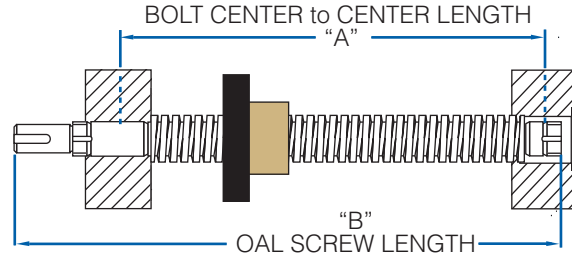

NOTE: "A" & "B" Dimensions reflect a 1/2" over travel at each end.

DIA-TPI	BOLT CENTER "A"	O.A.L. "B"	REF. NUMBER BRONZE NUT	REF. NUMBER PLASTIC NUT	Page
3/8 - 2	2.62" + Travel	4.4" + Travel	037 - RA / EK / CN / "B" / 20037 / FS	037 - RA / EK / CN / "B" / 20037 / FS	20
3/8 - 4	2.62" + Travel	4.4" + Travel	034 - RA / EK / CN / "B" / 20034 / FS	034 - RA / EK / CN / "B" / 20034 / FS	20
3/8 - 5	2.62" + Travel	4.4" + Travel	035 - RA / EK / CN / "B" / 20035 / FS	035 - RA / EK / CN / "B" / 20035 / FS	20
3/8 - 6	2.62" + Travel	4.4" + Travel	036 - RA / EK / CN / "B" / 20036 / FS	036 - RA / EK / CN / "B" / 20036 / FS	21
3/8 - 8	2.62" + Travel	4.4" + Travel	038 - RA / EK / CN / "B" / 20038 / FS	038 - RA / EK / CN / "B" / 20038 / FS	21
3/8 - 10	2.62" + Travel	4.4" + Travel	030 - RA / EK / CN / "B" / 20030 / FS	030 - RA / EK / CN / "B" / 20030 / FS	21
3/8 - 12	2.62" + Travel	4.4" + Travel	032 - RA / EK / CN / "B" / 20032 / FS	032 - RA / EK / CN / "B" / 20032 / FS	21
3/8 - 16	2.62" + Travel	4.4" + Travel	033 - RA / EK / CN / "B" / 20033 / FS	033 - RA / EK / CN / "B" / 30033 / FS	21
7/16 - 2	2.75" + Travel	4.62" + Travel	—	042 - RA / EK / CN / "B" / 30042 / FS	22
7/16 - 4	2.75" + Travel	4.62" + Travel	044 - RA / EK / CN / "B" / 20044 / FS	044 - RA / EK / CN / "B" / 30044 / FS	22
1/2 - 1	2.87" + Travel	5.23" + Travel	—	051 - RA / EK / CN / "B" / 30051 / FS	23
1/2 - 2	2.87" + Travel	5.32" + Travel	052 - RA / EK / CN / "B" / 20052 / FS	052 - RA / EK / CN / "B" / 30052 / FS	23
1/2 - 4	2.75" + Travel	4.62" + Travel	054 - RA / EK / CN / "B" / 20054 / FS	054 - RA / EK / CN / "B" / 30054 / FS	23
1/2 - 5	2.87" + Travel	5.23" + Travel	055 - RA / EK / CN / "B" / 20055 / FS	055 - RA / EK / CN / "B" / 30055 / FS	23
1/2 - 10	2.87" + Travel	5.23" + Travel	050 - RA / EK / CN / "B" / 20050 / FS	050 - RA / EK / CN / "B" / 30050 / FS	23
5/8 - 2 2/3	3.12" + Travel	5.57" + Travel	063 - RA / EK / CN / "B" / 20063 / FS	063 - RA / EK / CN / "B" / 30063 / FS	24
5/8 - 5	3.12" + Travel	5.48" + Travel	065 - RA / EK / CN / "B" / 20065 / FS	065 - RA / EK / CN / "B" / 30065 / FS	24
5/8 - 8	3.12" + Travel	5.57" + Travel	068 - RA / EK / CN / "B" / 20068 / FS	068 - RA / EK / CN / "B" / 30068 / FS	24
5/8 - 10	3.38" + Travel	6.43" + Travel	060 - RA / EK / CN / "B" / 20060 / FS	060 - RA / EK / CN / "B" / 30060 / FS	24
3/4 - 2	3.63" + Travel	6.68" + Travel	072 - RA / EK / CN / "B" / 20072 / FS	072 - RA / EK / CN / "B" / 30072 / FS	25
3/4 - 3	3.63" + Travel	6.68" + Travel	073 - RA / EK / CN / "B" / 20073 / FS	073 - RA / EK / CN / "B" / 30073 / FS	25
3/4 - 5	3.63" + Travel	6.68" + Travel	075 - RA / EK / CN / "B" / 20075 / FS	075 - RA / EK / CN / "B" / 30075 / FS	25
3/4 - 6	3.63" + Travel	6.68" + Travel	076 - RA / EK / CN / "B" / 20076 / FS	076 - RA / EK / CN / "B" / 30076 / FS	25
3/4 - 10	3.63" + Travel	6.60" + Travel	070 - RA / EK / CN / "B" / 20070 / FS	070 - RA / EK / CN / "B" / 30070 / FS	25
7/8 - 6	3.88" + Travel	6.85" + Travel	086 - RA / EK / CN / "B" / 20086 / FS	086 - RA / EK / CN / "B" / 30086 / FS	26
1 - 1	4.22" + Travel	8.14" + Travel	111 - RA / EK / CN / "B" / 20111 / FS	111 - RA / EK / CN / "B" / 30111 / FS	27
1 - 2	4.18" + Travel	7.45" + Travel	112 - RA / EK / CN / "B" / 20112 / FS	111 - RA / EK / CN / "B" / 30112 / FS	27
1 - 4	4.18" + Travel	7.45" + Travel	104 - RA / EK / CN / "B" / 20104 / FS	112 - RA / EK / CN / "B" / 30104 / FS	27
1 - 5	4.18" + Travel	7.45" + Travel	105 - RA / EK / CN / "B" / 20105 / FS	104 - RA / EK / CN / "B" / 30105 / FS	27
1 - 6	4.18" + Travel	7.45" + Travel	106 - RA / EK / CN / "B" / 20106 / FS	105 - RA / EK / CN / "B" / 30106 / FS	27
1 - 10	4.22" + Travel	8.14" + Travel	110 - RA / EK / CN / "B" / 20110 / FS	106 - RA / EK / CN / "B" / 30106 / FS	27
1 1/8 - 5	4.28" + Travel	8.14" + Travel	115 - RA / EK / CN / "B" / 20115 / FS	110 - RA / EK / CN / "B" / 30110 / FS	27
1 1/4 - 4	4.47" + Travel	8.39" + Travel	124 - RA / EK / CN / "B" / 20124 / FS	115 - RA / EK / CN / "B" / 30115 / FS	28
1 1/4 - 5	4.69" + Travel	8.84" + Travel	125 - RA / EK / CN / "B" / 20125 / FS	124 - RA / EK / CN / "B" / 30124 / FS	29
1 1/2 - 2	5.24" + Travel	9.84" + Travel	152 - RA / EK / CN / "B" / 20152 / FS	125 - RA / EK / CN / "B" / 30125 / FS	29
1 1/2 - 2 2/3	5.24" + Travel	9.39" + Travel	153 - RA / EK / CN / "B" / 20153 / FS	152 - RA / EK / CN / "B" / 30152 / FS	30
1 1/2 - 4	5.24" + Travel	9.84" + Travel	154 - RA / EK / CN / "B" / 20154 / FS	153 - RA / EK / CN / "B" / 30153 / FS	30
1 1/2 - 5	5.24" + Travel	9.84" + Travel	155 - RA / EK / CN / "B" / 20155 / FS	154 - RA / EK / CN / "B" / 30154 / FS	30
1 1/2 - 10	5.24" + Travel	9.84" + Travel	150 - RA / EK / CN / "B" / 20150 / FS	155 - RA / EK / CN / "B" / 30155 / FS	30

The specifications and data in this publication are believed to be accurate and reliable. However, it is the responsibility of the product user to determine the suitability of Nook Industries products for a specific application. While defective products will be replaced without charge if promptly returned, no liability is assumed beyond such replacement.



CONVENIENCE AND MODULARITY

These PowerAc™ modular assemblies are pre-engineered and feature a 2-C acme screw, steel mounting flange with choice of nut material, one single and one double bearing EZZE-MOUNT™ support with motor mount. One end of the mounted screw is provided with a drive shaft and keyway for coupling the motor mount assembly.



Use the reference number below to select the assembly that meets the design requirement. See pages 214-218 for EZZE-MOUNT™ information and pages 212-213 for End Machining information.

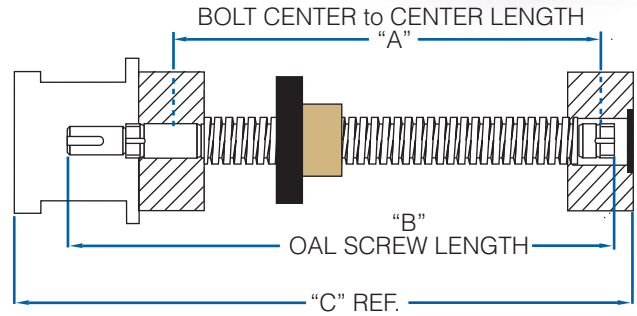

NOTE: "A" & "B" Dimensions reflect a 1/2" over travel at each end.

INCH ACME SCREW ASSEMBLIES TECHNICAL DATA

DIA-TPI	ADD MEASUREMENT BELOW + TRAVEL			REF. NUMBER BRONZE NUT	REF. NUMBER PLASTIC NUT	MOTOR MOUNT	Page
	BOLT CENTER "A"	O.A.L "B"	"C" REF.				
7/16 - 2	2.75"	4.62"	6.16"	—	042 - RA / U1 / CN / "B" / 30042 / FS	EZM-1008-17	22
7/16 - 4	2.75"	4.62"	6.16"	044 - RA / U1 / CN / "B" / 20044 / FS	044 - RA / U1 / CN / "B" / 30044 / FS	EZM-1008-17	22
1/2 - 1	2.87"	5.23"	7.04"	—	051 - RA / U2 / CN / "B" / 30051 / FS	EZM-1009-23	23
1/2 - 2	2.87"	5.32"	7.04"	052 - RA / U2 / CN / "B" / 20052 / FS	052 - RA / U2 / CN / "B" / 30052 / FS	EZM-3010-23	23
1/2 - 4	2.75"	4.62"	6.16"	054 - RA / U1 / CN / "B" / 20054 / FS	054 - RA / U1 / CN / "B" / 30054 / FS	EZM-1008-17	23
1/2 - 5	2.87"	5.23"	7.04"	055 - RA / U2 / CN / "B" / 20055 / FS	055 - RA / U2 / CN / "B" / 30055 / FS	EZM-1009-23	23
1/2 - 10	2.87"	5.23"	7.04"	050 - RA / U2 / CN / "B" / 20050 / FS	050 - RA / U2 / CN / "B" / 30050 / FS	EZM-1009-23	23
5/8 - 2 2/3	3.12"	5.57"	7.29"	063 - RA / U2 / CN / "B" / 20063 / FS	063 - RA / U2 / CN / "B" / 30063 / FS	EZM-3010-23	24
5/8 - 5	3.12"	5.48"	7.29"	065 - RA / U2 / CN / "B" / 20065 / FS	065 - RA / U2 / CN / "B" / 30065 / FS	EZM-1009-23	24
5/8 - 8	3.12"	5.57"	7.29"	068 - RA / U2 / CN / "B" / 20068 / FS	068 - RA / U2 / CN / "B" / 30068 / FS	EZM-3010-23	24
5/8 - 10	3.38"	6.43"	7.86"	060 - RA / U2 / CN / "B" / 20060 / FS	060 - RA / U2 / CN / "B" / 30060 / FS	EZM-3012-23	24
3/4 - 2	3.63"	6.68"	8.11"	072 - RA / U2 / CN / "B" / 20072 / FS	072 - RA / U2 / CN / "B" / 30072 / FS	EZM-3012-23	25
3/4 - 3	3.63"	6.68"	8.11"	073 - RA / U2 / CN / "B" / 20073 / FS	073 - RA / U2 / CN / "B" / 30073 / FS	EZM-3012-23	25
3/4 - 5	3.63"	6.68"	8.11"	075 - RA / U2 / CN / "B" / 20075 / FS	075 - RA / U2 / CN / "B" / 30075 / FS	EZM-3012-23	25
3/4 - 6	3.63"	6.68"	8.11"	076 - RA / U2 / CN / "B" / 20076 / FS	076 - RA / U2 / CN / "B" / 30076 / FS	EZM-3012-23	25
3/4 - 10	3.63"	6.60"	8.76"	070 - RA / U3 / CN / "B" / 20070 / FS	070 - RA / U3 / CN / "B" / 30070 / FS	EZM-3015-34	25
7/8 - 6	3.88"	6.85"	9.01"	086 - RA / U3 / CN / "B" / 20086 / FS	086 - RA / U3 / CN / "B" / 30086 / FS	EZM-3015-34	26
1 - 1	4.22"	8.14"	10.18"	111 - RA / U3 / CN / "B" / 20111 / FS	111 - RA / U3 / CN / "B" / 30111 / FS	EZM-2020-34	27
1 - 2	4.18"	7.45"	9.75"	112 - RA / U3 / CN / "B" / 20112 / FS	111 - RA / U3 / CN / "B" / 30112 / FS	EZM-3017-34	27
1 - 4	4.18"	7.45"	9.75"	104 - RA / U3 / CN / "B" / 20104 / FS	112 - RA / U3 / CN / "B" / 30104 / FS	EZM-3017-34	27
1 - 5	4.18"	7.45"	9.75"	105 - RA / U3 / CN / "B" / 20105 / FS	104 - RA / U3 / CN / "B" / 30105 / FS	EZM-3017-34	27
1 - 6	4.18"	7.45"	9.75"	106 - RA / U3 / CN / "B" / 20106 / FS	105 - RA / U3 / CN / "B" / 30106 / FS	EZM-3017-34	27
1 - 10	4.22"	8.14"	10.18"	110 - RA / U3 / CN / "B" / 20110 / FS	110 - RA / U3 / CN / "B" / 30110 / FS	EZM-2020-34	27
1 1/8 - 5	4.22"	8.14"	10.18"	115 - RA / U3 / CN / "B" / 20115 / FS	115 - RA / U3 / CN / "B" / 30115 / FS	EZM-2020-34	28
1 1/4 - 4	4.47"	8.39"	10.43"	124 - RA / U3 / CN / "B" / 20124 / FS	124 - RA / U3 / CN / "B" / 30124 / FS	EZM-2020-34	29
1 1/4 - 5	4.69"	8.14"	11.13"	125 - RA / U3 / CN / "B" / 20125 / FS	125 - RA / U3 / CN / "B" / 30125 / FS	EZM-3025-34	29
1 1/2 - 2	5.24"	9.84"	12.21"	152 - RA / U3 / CN / "B" / 20152 / FS	152 - RA / U3 / CN / "B" / 30152 / FS	EZM-2030-34	30
1 1/2 - 2 2/3	5.24"	9.39"	11.68"	153 - RA / U3 / CN / "B" / 20153 / FS	153 - RA / U3 / CN / "B" / 30153 / FS	EZM-3025-34	30
1 1/2 - 4	5.24"	9.84"	12.21"	154 - RA / U3 / CN / "B" / 20154 / FS	154 - RA / U3 / CN / "B" / 30154 / FS	EZM-2030-34	30
1 1/2 - 5	5.24"	9.84"	12.21"	155 - RA / U3 / CN / "B" / 20155 / FS	155 - RA / U3 / CN / "B" / 30155 / FS	EZM-2030-34	30
1 1/2 - 10	5.24"	9.84"	12.21"	150 - RA / U3 / CN / "B" / 20150 / FS	150 - RA / U3 / CN / "B" / 30150 / FS	EZM-2030-34	30

CONVENIENCE AND MODULARITY

These PowerAc™ modular assemblies are pre-engineered and feature a 2-C acme screw, steel mounting flange with choice of nut material, one single and one double bearing EZZE-MOUNT™ support. Drive end of the mounted screw is provided with a handwheel for manual operation.

Use the reference number below to select the assembly that meets the design requirement. See page 214-218 for EZZE-MOUNT™ information, page 212-213 for End Machining information and page 287 for handwheel dimensional information.

EXAMPLE:

072 - RA / EQ / CN / 29.62 / 20072 / FS

Is a 1/2"-2 Acme Right Hand Alloy Steel Rolled Screw with a Universal Double and a Universal Single EZZE-MOUNT™ overall length of 29.62" with a 3/4"-2 right hand acme nut and a handwheel 4" diameter.

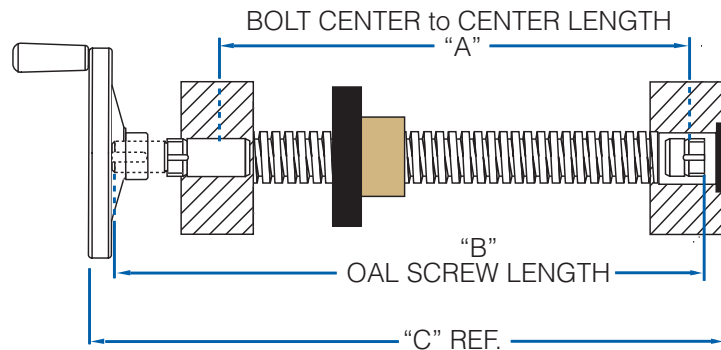

NOTE: "A" & "B" Dimensions reflect a 1/2" over travel at each end.

DIA-TPI	ADD MEASUREMENT BELOW + TRAVEL			REF. NUMBER BRONZE NUT	REF. NUMBER PLASTIC NUT	HANDWHEEL		PAGE
	BOLT CENTER "A"	O.A.L "B"	"C" REF.			SIZE	PART NO.	
5/8 - 10	3.38"	6.43"	7.17"	060 - RA / EQ / CN / "B" / 20060 / FS	060 - RA / EQ / CN / "B" / 30060 / FS	4"	H043*	24
3/4 - 2	3.63"	6.68"	7.42"	072 - RA / EQ / CN / "B" / 20072 / FS	072 - RA / EQ / CN / "B" / 30072 / FS	4"	H043	25
3/4 - 3	3.63"	6.68"	7.42"	073 - RA / EQ / CN / "B" / 20073 / FS	073 - RA / EQ / CN / "B" / 30073 / FS	4"	H043	25
3/4 - 5	3.63"	6.68"	7.42"	075 - RA / EQ / CN / "B" / 20075 / FS	075 - RA / EQ / CN / "B" / 30075 / FS	4"	H043	25
3/4 - 6	3.63"	6.68"	7.42"	076 - RA / EQ / CN / "B" / 20076 / FS	076 - RA / EQ / CN / "B" / 30076 / FS	4"	H043	25
3/4 - 10	3.63"	6.60"	7.31"	070 - RA / EQ / CN / "B" / 20070 / FS	070 - RA / EQ / CN / "B" / 30070 / FS	4"	H044	25
7/8 - 6	3.88"	6.85"	7.81"	086 - RA / EQ / CN / "B" / 20086 / FS	086 - RA / EQ / CN / "B" / 30086 / FS	6"	H064	26
1 - 1	4.22"	8.14"	9.00"	111 - RA / EQ / CN / "B" / 20111 / FS	111 - RA / EQ / CN / "B" / 30111 / FS	6"	H065**	27
1 - 2	4.18"	7.45"	8.59"	112 - RA / EQ / CN / "B" / 20112 / FS	111 - RA / EQ / CN / "B" / 30112 / FS	6"	H064	27
1 - 4	4.18"	7.45"	8.59"	104 - RA / EQ / CN / "B" / 20104 / FS	112 - RA / EQ / CN / "B" / 30104 / FS	6"	H064	27
1 - 5	4.18"	7.45"	8.59"	105 - RA / EQ / CN / "B" / 20105 / FS	104 - RA / EQ / CN / "B" / 30105 / FS	6"	H064	27
1 - 6	4.18"	7.45"	8.59"	106 - RA / EQ / CN / "B" / 20106 / FS	105 - RA / EQ / CN / "B" / 30106 / FS	6"	H064	27
1 - 10	4.22"	8.14"	9.00"	110 - RA / EQ / CN / "B" / 20110 / FS	110 - RA / EQ / CN / "B" / 30110 / FS	6"	H065**	27
1 1/8 - 5	4.22"	8.14"	9.00"	115 - RA / EQ / CN / "B" / 20115 / FS	115 - RA / EQ / CN / "B" / 30115 / FS	6"	H065**	28
1 1/4 - 4	4.47"	8.39"	9.25"	124 - RA / EQ / CN / "B" / 20124 / FS	124 - RA / EQ / CN / "B" / 30124 / FS	6"	H065**	29
1 1/4 - 5	4.69"	8.14"	9.89"	125 - RA / EQ / CN / "B" / 20125 / FS	125 - RA / EQ / CN / "B" / 30125 / FS	8"	H086	29
1 1/2 - 2	5.24"	9.84"	10.85"	152 - RA / EQ / CN / "B" / 20152 / FS	152 - RA / EQ / CN / "B" / 30152 / FS	8"	H088	30
1 1/2 - 2 2/3	5.24"	9.39"	10.44"	153 - RA / EQ / CN / "B" / 20153 / FS	153 - RA / EQ / CN / "B" / 30153 / FS	8"	H086	30
1 1/2 - 4	5.24"	9.84"	10.85"	154 - RA / EQ / CN / "B" / 20154 / FS	154 - RA / EQ / CN / "B" / 30154 / FS	8"	H088	30
1 1/2 - 5	5.24"	9.84"	10.85"	155 - RA / EQ / CN / "B" / 20155 / FS	155 - RA / EQ / CN / "B" / 30155 / FS	8"	H088	30
1 1/2 - 10	5.24"	9.84"	10.85"	150 - RA / EQ / CN / "B" / 20150 / FS	150 - RA / EQ / CN / "B" / 30150 / FS	8"	H088	30

* Indicates modified Type III End Machining required.

** H065 handwheel has the same outer dimensions as H064, but different bore.

Other combinations of screw assemblies and handwheels are available upon request.