

ND8-12-40-A

Call 800-321-7800 or visit us online at www.nookindustries.com to configure and order your ND8-12-40-A today!

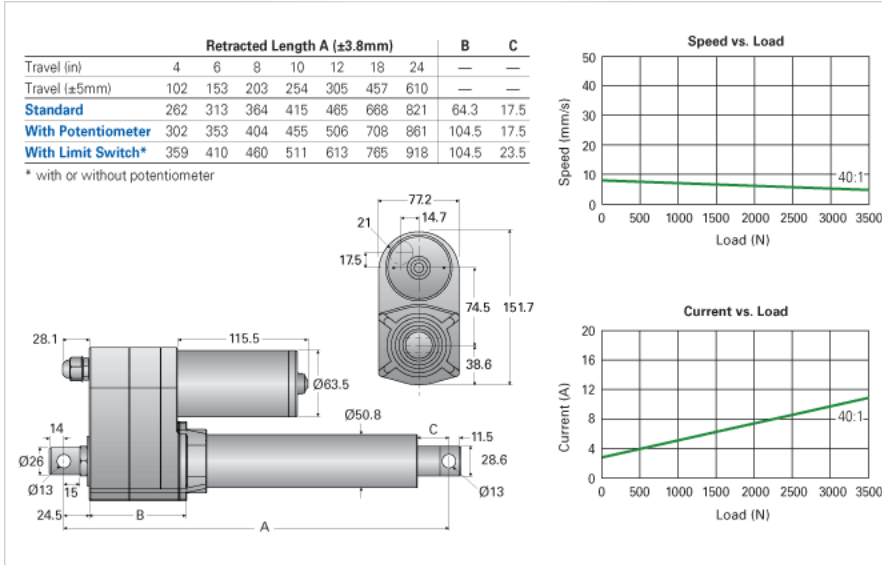

Product Info

Screw Type

Acme Screw

Details

Voltage [VDC]

12

Gear Ratio

40:1

Speed At No Load [mm/s]

8.4

Speed At Full Load [mm/s]

7.4

Load Capacity Dynamic Load [N]

3500

Load Capacity Static Load [N]

4500

Amps

11

Performance Specifications

Duty Cycle [% of 5 Minutes]

25

Protection Class

IP65