

RAD-5046-HD

Call 800-321-7800 or visit us online at www.nookindustries.com to configure and order your RAD-5046-HD today!

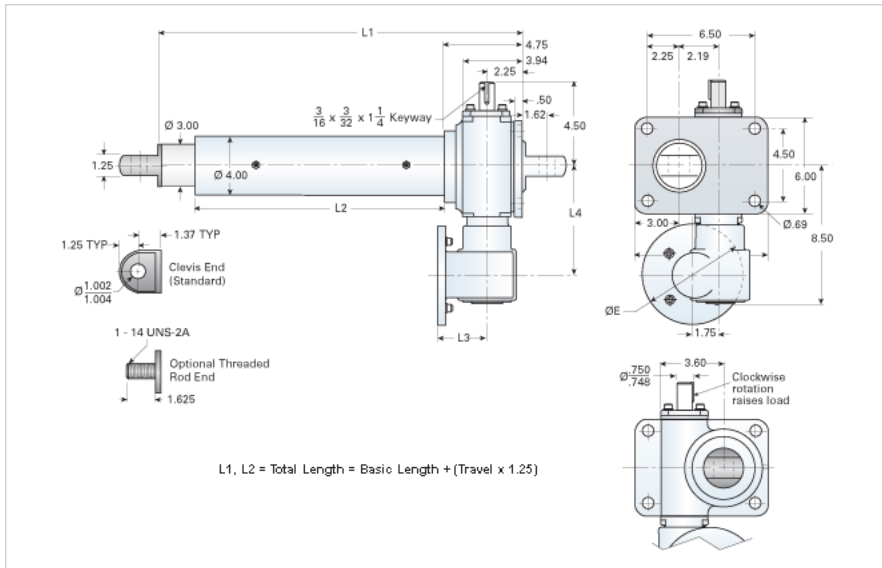

Details

| | |
|--------------------------------|------------------|
| Gear Ratio Primary Reduction | 24:1 |
| Gear Ratio Secondary Reduction | 6:1 |
| Max Capacity [lb] | 10000 |
| Input Turns Per Inch Of Travel | 304 |
| Torque To Raise 1 lb. [in-lb] | 0.0019 |
| Ball Screw | 1500-0473 SRT RA |
| Screw Lead [in] | 0.413 |
| Root Diameter [in] | 1.140 |
| Max HP [hp] | 1 |

Weight

| | |
|-------------------------|------|
| Basic Weight [lb] | 77 |
| Per Inch of Travel [lb] | 1.92 |

Tube Dimensions

| | |
|----------------------|-------|
| L1 Basic Length [in] | 15.13 |
| L2 Basic Length [in] | 8.88 |

NEMA 56C Dimensions

| | |
|---------|------|
| L3 [in] | 3.69 |
| L4 [in] | 6.50 |
| E [in] | 6.69 |

NEMA 180TC Dimensions

| | |
|---------|---|
| L3 [in] | - |
| L4 [in] | - |
| F [in] | - |