

## RAD-20088-HL/50XX

Call 800-321-7800 or visit us online at [www.nookindustries.com](http://www.nookindustries.com) to configure and order your RAD-20088-HL/50XX today!

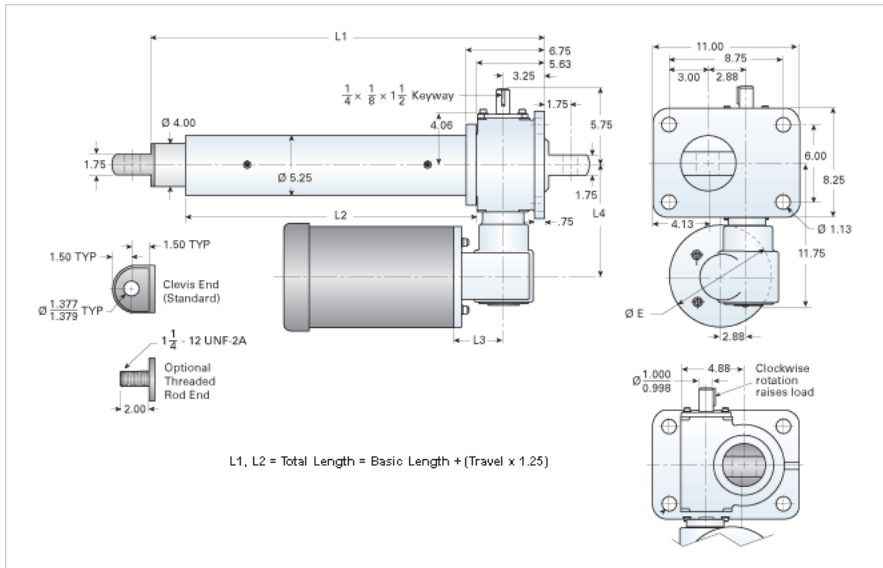

### Performance Specifications

Travel Rate [in/min]	27
Dynamic Capacity [lb]	30000
Rated Life [in]	690000
Motor Horse Power	5
Maximum Rod Reaction Torque [in-lb]	5300
Std. Brake Torque [ft-lb]	15
Approximate Stopping Distance No Load [in]	0.09
Approximate Stopping Distance Full Load [in]	0.09

### Details

Gear Ratio Primary Reduction	8:1
Gear Ratio Secondary Reduction	8:1
Input Turns Per Inch Of Travel	64
Torque To Raise 1 lb. [in-lb]	0.0062
Max Capacity [lb]	40000
Max HP [hp]	5

### Weight

Basic Weight [lb]	202
Per Inch of Travel [lb]	3.31

### Tube Dimensions

L1 Basic Length [in]	21.13
L2 Basic Length [in]	12.63

### NEMA 56C Dimensions

L3 [in]	6.12
L4 [in]	9.00
E [in]	9.12

### NEMA 180TC Dimensions

L3 [in]	-
L4 [in]	-
F [in]	-